

Service Manual

Paper Deck

Paper Deck-Q1

Canon

Application

This manual has been issued by Canon Inc. for qualified persons to learn technical theory, installation, maintenance, and repair of products. This manual covers all localities where the products are sold. For this reason, there may be information in this manual that does not apply to your locality.

Corrections

This manual may contain technical inaccuracies or typographical errors due to improvements or changes in products. When changes occur in applicable products or in the contents of this manual, Canon will release technical information as the need arises. In the event of major changes in the contents of this manual over a long or short period, Canon will issue a new edition of this manual.

The following paragraph does not apply to any countries where such provisions are inconsistent with local law.

Trademarks

The product names and company names used in this manual are the registered trademarks of the individual companies.

Copyright

This manual is copyrighted with all rights reserved. Under the copyright laws, this manual may not be copied, reproduced or translated into another language, in whole or in part, without the written consent of Canon Inc.

COPYRIGHT © 2001 CANON INC.









Printed in Japan

Caution

Use of this manual should be strictly supervised to avoid disclosure of confidential information.



Symbols Used

This documentation uses the following symbols to indicate special information:

Symbol	Description
	Indicates an item of a non-specific nature, possibly classified as Note, Caution, or Warning.
	Indicates an item requiring care to avoid electric shocks.
	Indicates an item requiring care to avoid combustion (fire).
	Indicates an item prohibiting disassembly to avoid electric shocks or problems.
	Indicates an item requiring disconnection of the power plug from the electric outlet.
 Memo	Indicates an item intended to provide notes assisting the understanding of the topic in question.
 REF.	Indicates an item of reference assisting the understanding of the topic in question.
	Provides a description of a service mode.
	Provides a description of the nature of an error indication.

The following rules apply throughout this Service Manual:

1. Each chapter contains sections explaining the purpose of specific functions and the relationship between electrical and mechanical systems with reference to the timing of operation.

In the diagrams,  represents the path of mechanical drive; where a signal name accompanies the symbol, the arrow  indicates the direction of the electric signal.

The expression "turn on the power" means flipping on the power switch, closing the front door, and closing the delivery unit door, which results in supplying the machine with power.

2. In the digital circuits, '1' is used to indicate that the voltage level of a given signal is "High", while '0' is used to indicate "Low". (The voltage value, however, differs from circuit to circuit.) In addition, the asterisk (*) as in "DRMD*" indicates that the DRMD signal goes on when '0'.

In practically all cases, the internal mechanisms of a microprocessor cannot be checked in the field. Therefore, the operations of the microprocessors used in the machines are not discussed: they are explained in terms of from sensors to the input of the DC controller PCB and from the output of the DC controller PCB to the loads.

The descriptions in this Service Manual are subject to change without notice for product improvement or other purposes, and major changes will be communicated in the form of Service Information bulletins.

All service persons are expected to have a good understanding of the contents of this Service Manual and all relevant Service Information bulletins and be able to identify and isolate faults in the machine."

Contents

Chapter 1 Specifications

1.1 Product Specifications	1- 1
1.1.1 Specifications	1- 1
1.2 Names of Parts.....	1- 2
1.2.1 Names of Components	1- 2

Chapter 2 Functions

2.1 Basic Operation	2- 1
2.1.1 Pickup Operation	2- 1
2.1.2 Controlling the Deck Main Motor (M1D).....	2- 2
2.1.3 Controlling the Deck Lifter Motor (M2D).....	2- 3
2.2 Paper Detection	2- 5
2.2.1 Detecting the Presence/Absence of Paper	2- 5
2.2.2 Switching the Deck Paper Size	2- 5
2.2.3 Detecting the Level of Paper	2- 5
2.3 Deck Lifter	2- 7
2.3.1 Detecting the Presence/Absence of Paper	2- 7
2.4 Opening /Closing the Compartment.....	2- 9
2.4.1 Opening/Closing the Compartment.....	2- 9
2.5 Detecting Jams	2- 11
2.5.1 Overview	2- 11
2.6 Power Supply	2- 13
2.6.1 Power Supply Route.....	2- 13

Chapter 3 Installation

3.1 Unpacking and Installation.....	3- 1
3.1.1 Unpacking and Chacking the Components.....	3- 1
3.1.2 Installation Procedure	3- 2
3.1.3 Making Adjustments.....	3- 10

Chapter 4 Parts Replacement Procedure

4.1 Removing from the Host Machine	4- 1
4.1.1 Paper Deck-Q1	4- 1
4.2 Drive System	4- 3
4.2.1 Deck Pickup Clutch	4- 3
4.2.2 Deck Feed Clutch.....	4- 4
4.2.3 Deck Main Motor.....	4- 6
4.2.4 Deck Lifter Motor	4- 7
4.2.5 Lifter Cable (Front).....	4- 9
4.2.6 Lifter Cable	4- 11

4.3 Document Feeding System	4- 16
4.3.1 Deck Pickup Unit	4- 16
4.3.2 Deck Pickup Roller	4- 17
4.3.3 Deck Pickup/Feed Roller	4- 20
4.3.4 Deck Separation Roller	4- 22
4.4 Electrical System	4- 24
4.4.1 Deck Driver PCB	4- 24
4.4.2 Open Switch PCB.....	4- 24

Chapter 5 Maintenance

5.1 Maintenance and Inspection	5- 1
5.1.1 Periodically Replaced Parts.....	5- 1
5.1.2 Durables	5- 1
5.2 Adjustment.....	5- 2
5.2.1 Basic Adjustment	5- 2
5.2.2 Adjustment at Time of Parts Replacement.....	5- 5
5.3 Outline of Electrical Components	5- 7
5.3.1 Sensor-Motor-Clutch -Solenoid-PCB-Others.....	5- 7

Chapter 6 Service Mode

6.1 Outline	6- 1
6.1.1 Alarm Code.....	6- 1

Chapter 7 Error Code

7.1 Overview.....	7- 1
7.1.1 Error Code	7- 1

Chapter 1 Specifications

Contents

1.1 Product Specifications	1-1
1.1.1 Specifications	1-1
1.2 Names of Parts.....	1-2
1.2.1 Names of Components	1-2

1.1 Product Specifications

1.1.1 Specifications

0001-7292

T-1-1

Item	Description
Stack	2500 sheets (A4/LTR; 80 g/m2 paper)
Operation	in response to control signals from host machine's DC controller
Drive	from lifter deck lifter 2 motor of deck (M2D)
paper pickup/feed	by deck main motor (M1D)

1.2 Names of Parts

1.2.1 Names of Components

0001-6481

External cover

- [1] Deck release grip
- [2] Front cover (upper)
- [3] Compartment open/close switch
- [4] Front cover
- [5] Right cover
- [6] Upper cover
- [7] Rear cover
- [8] Left rear cover
- [9] Left upper cover

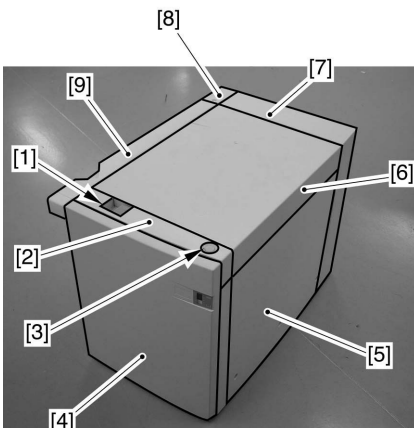

F-1-1

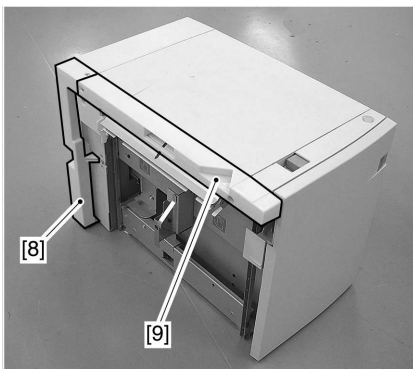

F-1-2

Chapter 2 Functions

Contents

2.1 Basic Operation	2-1
2.1.1 Pickup Operation	2-1
2.1.2 Controlling the Deck Main Motor (M1D)	2-2
2.1.3 Controlling the Deck Lifter Motor (M2D)	2-3
2.2 Paper Detection	2-5
2.2.1 Detecting the Presence/Absence of Paper	2-5
2.2.2 Switching the Deck Paper Size	2-5
2.2.3 Detecting the Level of Paper	2-5
2.3 Deck Lifter	2-7
2.3.1 Detecting the Presence/Absence of Paper	2-7
2.4 Opening /Closing the Compartment	2-9
2.4.1 Opening/Closing the Compartment	2-9
2.5 Detecting Jams	2-11
2.5.1 Overview	2-11
2.6 Power Supply	2-13
2.6.1 Power Supply Route	2-13

2.1 Basic Operation

2.1.1 Pickup Operation

0001-0806

The stack of paper deposited in the deck is raised by the lifter and held at a specific point for pickup. The deck pickup clutch (CL2D) goes on when the Start key is pressed.

The deck main motor (M1D) goes on to rotate the pickup roller to pick up paper.

The pickup/feed rollers and the separation roller make sure that only a single sheet of paper is sent forward. The deck pickup sensor (PS1S) is used to detect paper. The pickup roller leaves the stack of paper when the deck pickup roller release solenoid (SL1D) goes on. When paper is sent forward, the deck feed clutch (CL1D) goes on to rotate the deck feed roller so that the paper is moved as far as the host machine's registration roller, where it is arched to remove any skew.

The registration roller is used to make sure that the leading edge of paper will match the image on the photosensitive drum.

<if pickup is not detected within a specific period of time>

If, for some reason, the deck pickup sensor (PS6D) does not detect paper in the presence of the deck pickup detection signal, the machine will issue an alarm code.

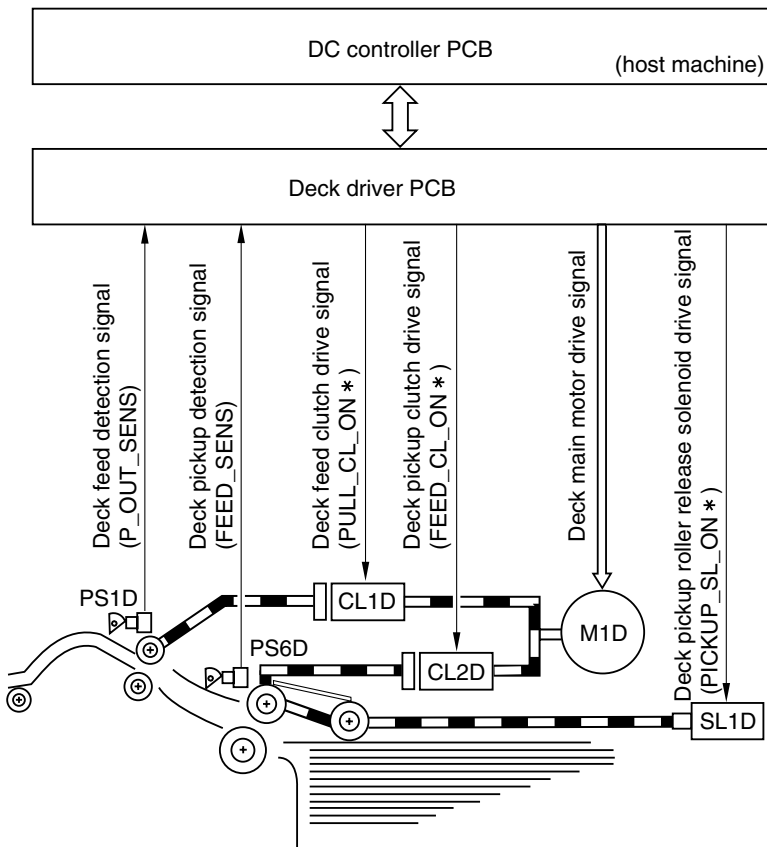

F-2-1

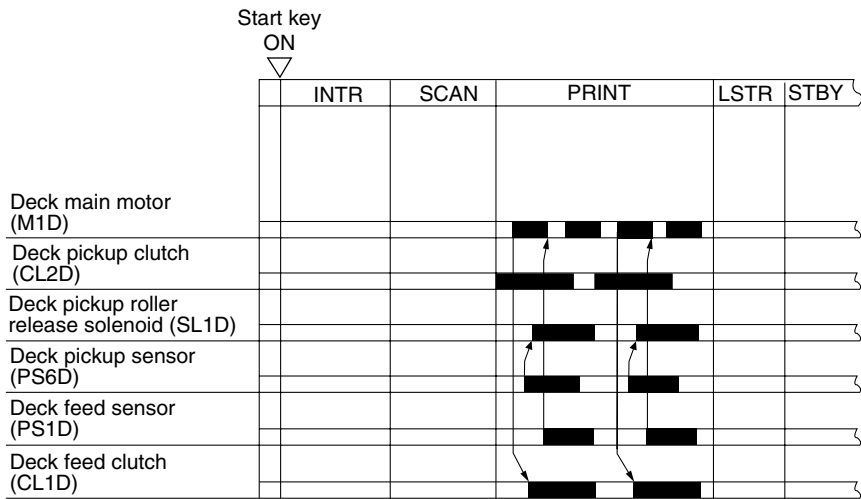

F-2-2

2.1.2 Controlling the Deck Main Motor (M1D)

0001-0832

The following diagram shows the circuit used to drive the deck main motor:

The serial signal from the host machine is used to control the following signals to turn on/off the deck main motor and switch the speed of its rotation: FEE_M_A, FEED_M_A*, FEED_M_B, FEED_M_B*.

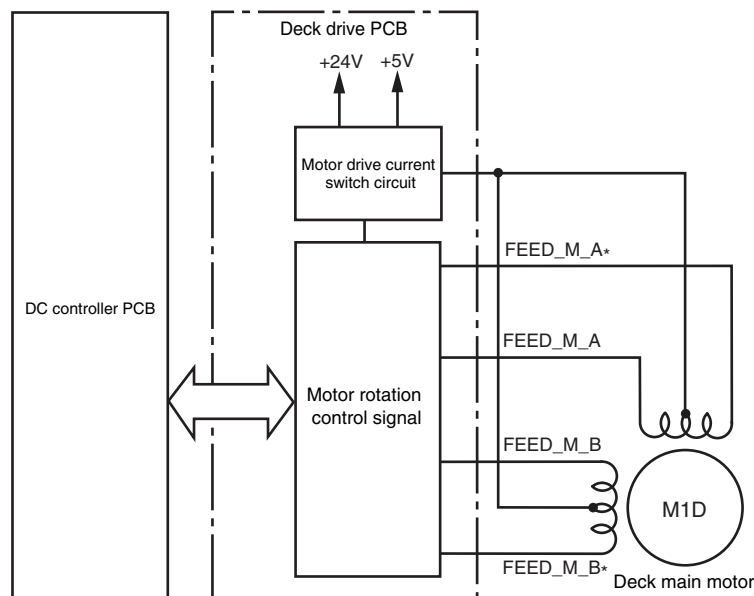

F-2-3

2.1.3 Controlling the Deck Lifter Motor (M2D)

0001-0835

The deck lifter motor is controlled by the deck driver circuit.

The deck lifter motor is rotated clockwise/counterclockwise using the following signals:

- output signals from various sensors

- deck lifter drive command/deck lifter up command (signals from the host machine's DC controller)

1. Moving Up the Lifter (a through e must be satisfied)

a) the deck is connected to the host machine.

deck set signal (DECK_MOUNT_SENS)="1"

b) the compartment is closed.

deck open detection signal (DECK_OPEN_SENS)="1"

deck open detecting switch (DECK_OPEN_SW)="ON"

c) the deck lifter upper limit detection signal (LIFT_M_UPLMT)="0"

and, in addition, deck lifter position detention signal (PAP_TOP_SENS)="0"

d) deck lifter motor down signal (LIFT_M_DOWN)="0"

e) deck lifter up signal (LIFT_M_UP*)="0"

2. Moving Down the Lifter (a through d must be satisfied)

a) the compartment is open.

deck open detection signal (DECK_OPEN_SENS)="0"

b) deck lifter lower limit signal (LIFT_LOW_LMT)="0"

and, in addition, deck lifter position detection signal (PAP_TOP_SENS)="0"

c) deck lifter motor down signal (LIFT_M_DOWN)="1"

d) deck lifter up signal (LIFT_M_UP*)"="1"

<if the lifter is not detected within a specific period of time>

If, for some reason, the deck lifter position sensor (PS4D) does not detect the lifter in the presence of the deck lifter up signal, the machine issues an alarm code.

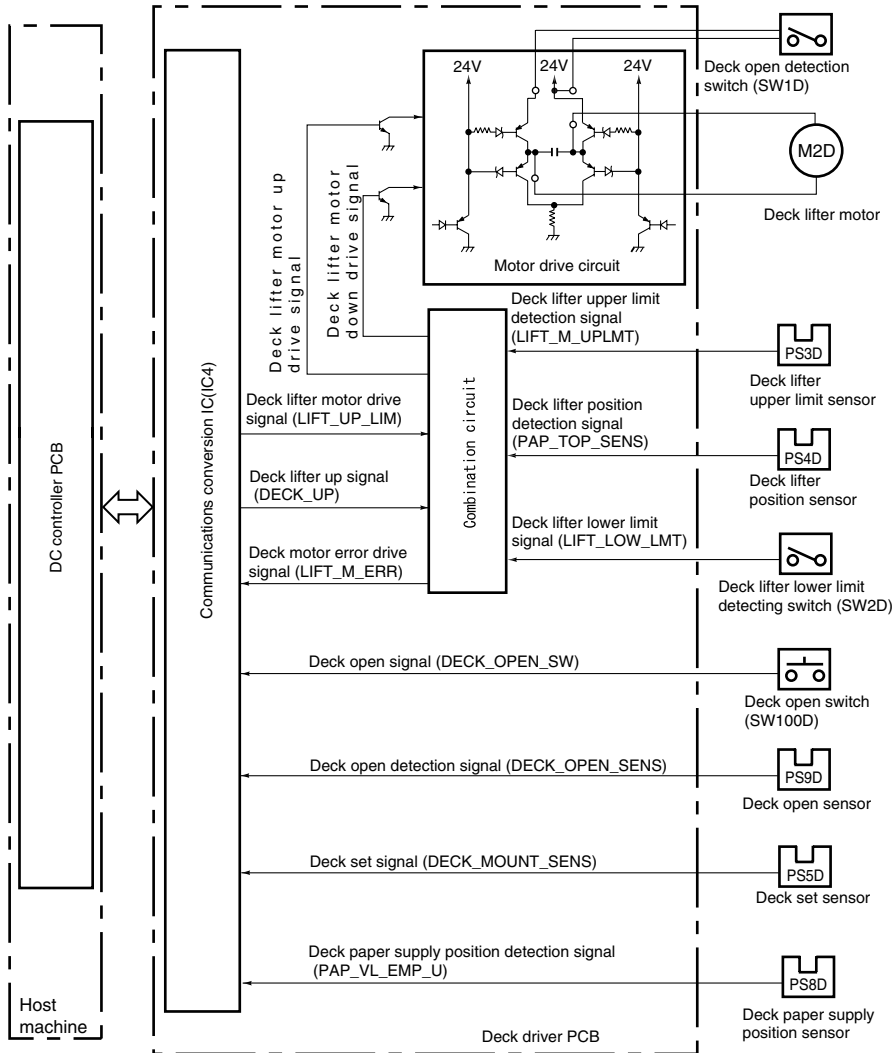

Note: The communications conversion IC (IC4) in the diagram is used for conversion between serial and parallel signals.

F-2-4

2.2 Paper Detection

2.2.1 Detecting the Presence/Absence of Paper

0001-0786

The deck paper absent sensor [1] (PS2D) is used to detect the presence/absence of paper.

The paper [3] deposited on the lifter [2] runs out.

The paper detecting lever [4] of the pickup roller assembly moves past the deck paper absent sensor.

The machine indicates a message to indicate the absence of paper (on the host machine's control panel).

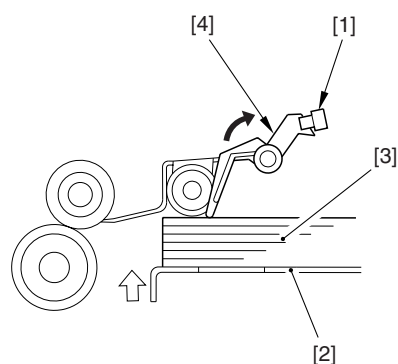

F-2-5

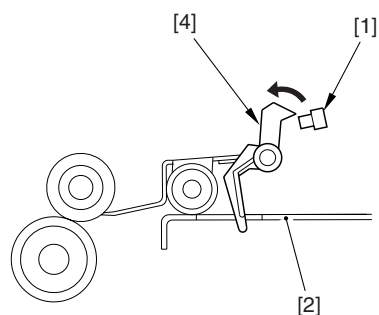

F-2-6

2.2.2 Switching the Deck Paper Size

0001-0790

Enter the appropriate paper size in service mode (OPTION>ACC>DK-P).

Move the guide plate inside the deck to suit the paper size, and enter the size in service mode (at time of installation or at the request of the user).

2.2.3 Detecting the Level of Paper

0001-0793

The following sensors are used to detect the level of paper:

- deck paper supply position sensor (PS8D)
- deck paper level sensor (PS7D)

- deck paper absent sensor

The mechanism of detection can indicate an approximate level of paper inside the compartment on the host machine's control panel.

T-2-1

Paper level	PS2D	PS8D	PS7D	Indication on control panel
100% to about 50%	1	1	1	☰
about 50% to about 10%	1	1	0	☱
about 10% or less	1	0	0	☲
no paper	0	0	0	☳

2.3 Deck Lifter

2.3.1 Detecting the Presence/Absence of Paper

0001-0798

The deck's lifter detects the presence/absence of paper as follows:

T-2-2

operation:	moved up or down by switching the direction of rotation of the deck lifter motor (M2D).
drive:	obtained from the deck lifter motor (M2D) through cable and reel.

1. Moving Up the Lifter

The compartment is pushed inside the deck.

The deck open detecting switch (SW1D) is pressed.

The deck open sensor (PS9D) detects the light-blocking plate.

- Stopping the Lifter

The deck lifter position sensor (PS4D) detects the top surface of the stack of paper to stop the lifter.

<preventing damage to the deck caused by excess ascent>

An upper limit is set, and it is detected using the deck lifter upper limit sensor (PS3D) in consideration of the following:

The sensor lever blocks the deck lifter position sensor for some reason (i.e., the lifter fails to stop its ascent).

2. Moving Down the Lifter

The deck open switch (SW100D) is pressed.

- Stopping the Lifter

The lifter stops where the lifter moves past the sensor lever of the deck paper supply position sensor (PS8D); i.e., at the falling edge of sensor output.

<addition of paper in this condition>

The added paper pushes the lever of the deck paper supply position sensor (PS8D).

The lifter moves farther down until the stack of paper moves past the sensor lever.

3. Adding Paper

Each time paper is added, the lifter repeats moving down until the deck lifter lower limit detecting switch (SW2D) is pressed (i.e., maximum paper supply level).

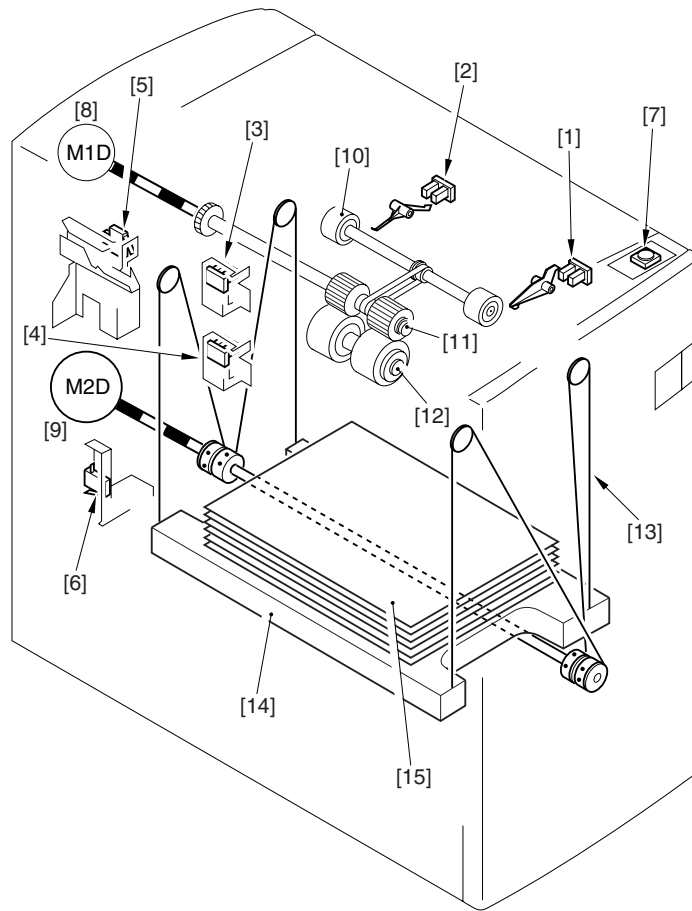

F-2-7

T-2-3

- | | |
|---|-----------------------------|
| [1] Deck lifter upper limit sensor (PS3D) | [9] Deck lifter motor (M2D) |
| [2] Deck lifter position sensor (PS4D) | [10] Pickup roller |
| [3] Deck paper supply position sensor (PS8D) | [11] Feed roller |
| [4] Deck paper level sensor (PS7D) | [12] Separation roller |
| [5] Deck open detecting switch (SW1D) | [13] Deck lifter cable |
| [6] Deck lifter lower limit detecting switch (SW2D) | [14] Lifter |
| [7] Deck open switch (SW100D) | [15] Paper |
| [8] Deck main motor (M1D) | |

2.4 Opening /Closing the Compartment

2.4.1 Opening/Closing the Compartment

0001-0814

<opening the compartment>

The deck open switch (SW100D) is pressed.

The deck open solenoid (SL2D) goes on.

The compartment is unlocked, and the force of the spring pushes it several centimeters toward the front.

The deck lifter motor (M2D) starts to rotate.

The lifter inside the compartment moves down.

<closing the compartment>

The compartment is pushed inside the deck.

The deck open sensor (PS9D) detects the light-blocking plate inside the compartment.

The lifter moves up to the pickup motor.

<deck open indicator (LED100D) goes on or flashes>

The deck open indicator is used to indicate that the deck lifter motor is rotating to open/close the deck.

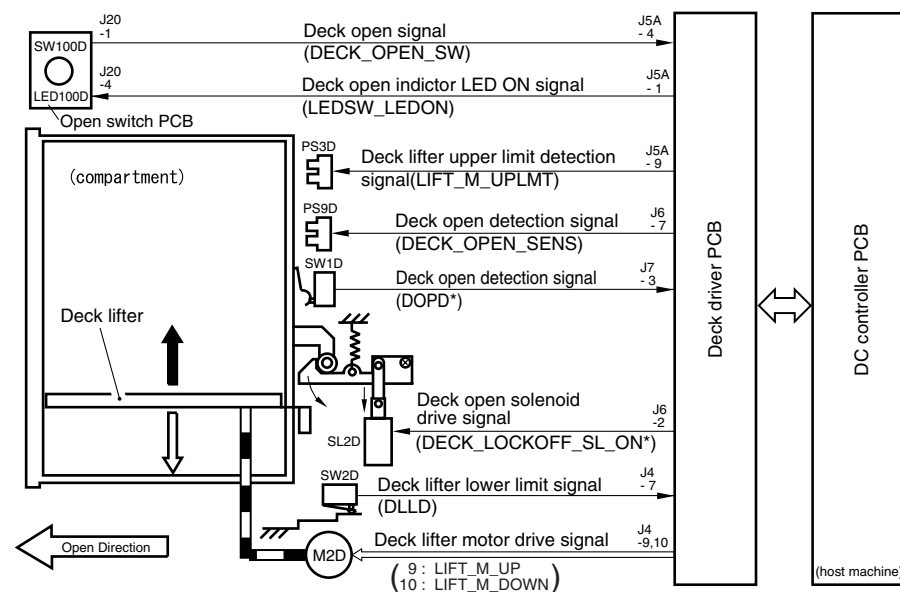

F-2-8

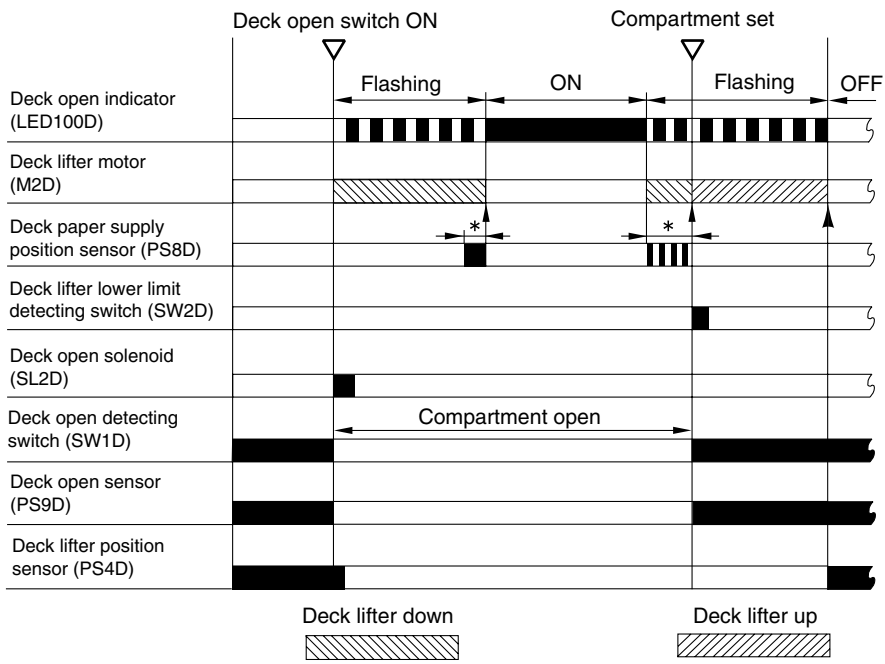

* : varies depending on the level of paper.

F-2-9

2.5 Detecting Jams

2.5.1 Overview

0001-0817

The paper deck is equipped with 2 sensors.

The machine reads the signals from the sensors at such times as programmed in the host machine's DC controller.

The machine decides whether the movement of paper is normal or not by using the host machine's DC controller.

<if a jam is identified>

The machine delivers the paper moving ahead of the jam, and then stops its operation. Thereafter, it indicates instructions on the removal of the jam using the host machine's control panel.

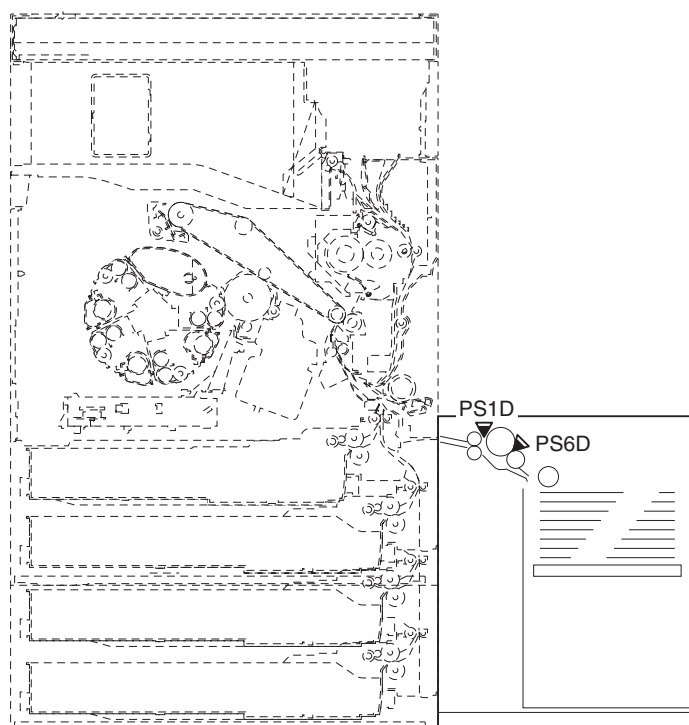

F-2-10

T-2-4

Notation	Name	Function
PS1D	deck feed sensor	checks for delay/stationary jams
PS6D	deck pickup sensor	checks for delay/stationary jams

The host machine's DC controller identifies a jam in response to the following:

1. there is paper over the deck feed sensor (PS6D) when the host machine is turned on or image stabilization control

is being executed.

2. Deck Pickup/Delay Jam

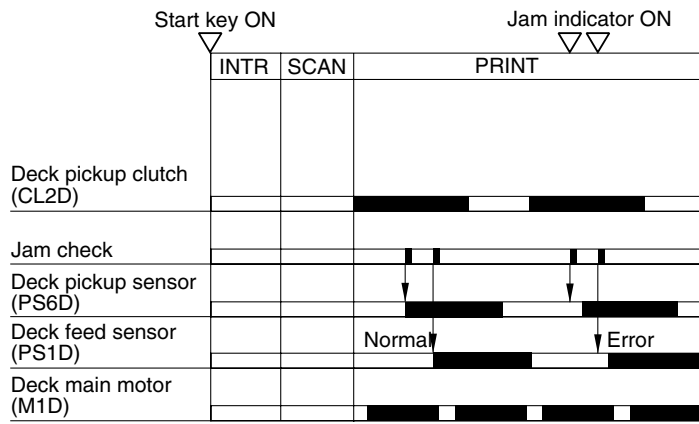

F-2-11

3. Deck Pickup/Vertical Path Stationery Jam

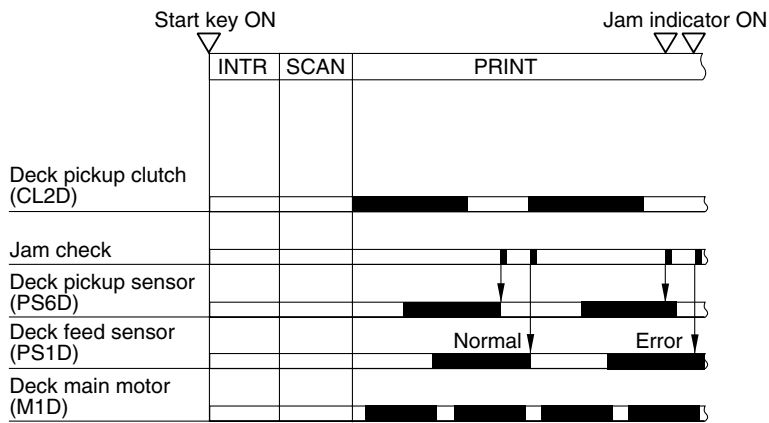

F-2-12

2.6 Power Supply

2.6.1 Power Supply Route

0001-6970

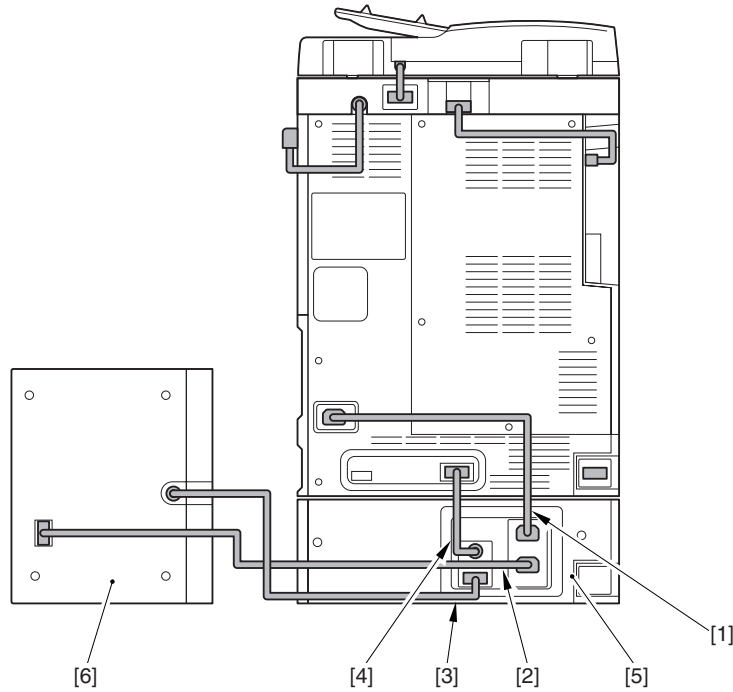

F-2-13

- [1] Pickup heater cable
- [2] Side deck heater cable
- [3] Side deck I/F cable
- [4] Cassette pedestal I/F cable
- [5] 2-Cassette Pedestal-K1
- [6] Side Paper Deck-Q1

Chapter 3 Installation

Contents

3.1 Unpacking and Installation.....	3-1
3.1.1 Unpacking and Chacking the Components	3-1
3.1.1.1 Unpacking and Checking the Components	3-1
3.1.2 Installation Procedure.....	3-2
3.1.2.1 Attaching to the Host Machine.....	3-2
3.1.3 Making Adjustments	3-10
3.1.3.1 Switching the Paper Size	3-10
3.1.3.2 Adjusting the Horizontal	3-11
3.1.3.3 A.Adjusting Horizontal Registration of the 1st Face (Mechanical Adjustment)	3-11
3.1.3.4 Adjusting Horizontal Registration of the Back Side Paper (2nd face).....	3-11
3.1.3.5 Adjusting the Mounting Position of the Front Cover	3-12
3.1.3.6 Adjusting the Side Roller Height	3-12

3.1 Unpacking and Installation

[1]

3.1.1 Unpacking and Checking the Components

3.1.1.1 Unpacking and Checking the Components [0004-6573](#)

Open the package of the machine, and check to make sure that the following parts are all included.

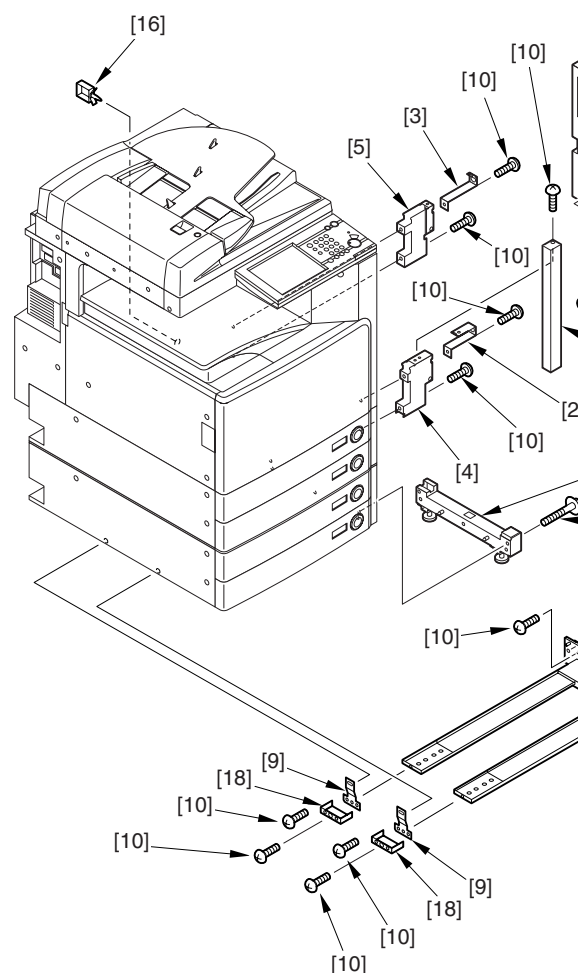

F-3-1

T-3-1

[1]	Paper Deck-Q1	1pc
[2]	Pin Support (Front)	1pc.
[3]	Pin Support (Rear)	1pc.
[4]	Latch Support (Front)	1pc.
[5]	Latch Support (Rear)	1pc.
[6]	Deck Mount	1pc.
[7]	Roller Support Plate	1pc.

[8]	Paper Size Label	1pc.
[9]	Fixing Hardware	2pc.
[10]	Binding Screw(M4x6)	17pc.
[11]	RS Tightening Screw (M4x33)	5pc.
[12]	Right Cover	1pc.
[13]	Open Label	1pc.
[14]	Slope Guide (Upper)	1pc.
[15]	Connect Stay	1pc.
[16]	Wire Saddle	1pc.
[17]	Deck Cover (Right Front)	1pc.
[18]	Mount Protection Cover	2pc.
[19]	Lifter Plate Sheet (A4 machine only)	1pc.

3.1.2 Installation Procedure

3.1.2.1 Attaching to the Host

Machine 0004-6640

1) Remove the inner blanking cover of the host machine.

1-1) Open the right door of the host machine, and open the lower right door of the 2-level cassette pedestal; Remove the lock [1] to the arrow direction shown in the fig.

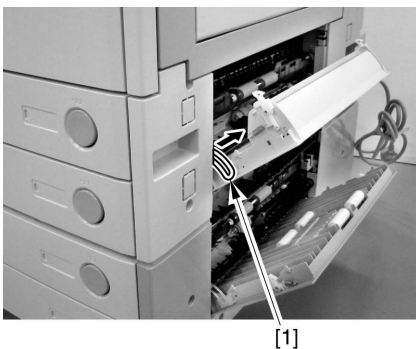

F-3-2

1-2) Remove the right door.

1-3) Remove the 2 screws [1] of the right door, and detach the inner blanking plate [3] while pushing

the 2 claws [2].

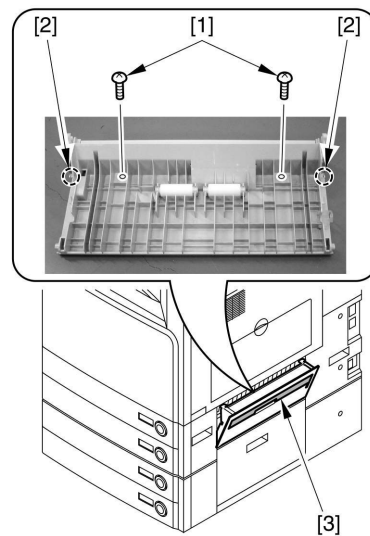

F-3-3

1-4) Attach the right door to the main unit, and then attach the lock.

2) Remove the 2 right covers (lower right [1], lower rear [2]) of the host machine.

3) Remove the 4 blanking parts [3] found at the 2 right covers with nippers or the like.

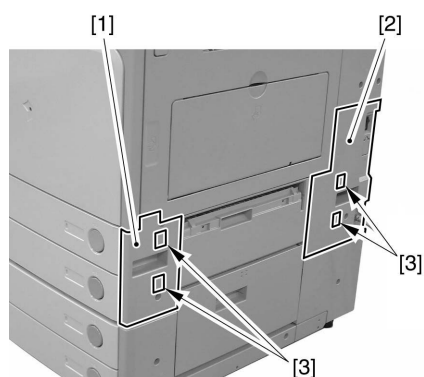

F-3-4

- 4) Attach the 2 right covers.
- 5) Close the right door of the host machine; close the lower right door.
- 6) Attach the latch support [1] and pin support (front) [2] with the 2 screws (M4x6) [3] included in the package.

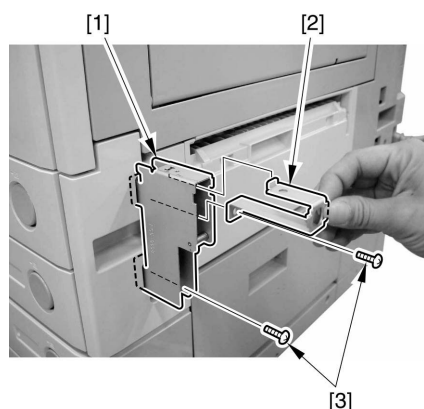

F-3-5

- 7) Attach the latch support [1] and pin support (rear) [2] with the 2 screws (M4x6) [3] included in the package.

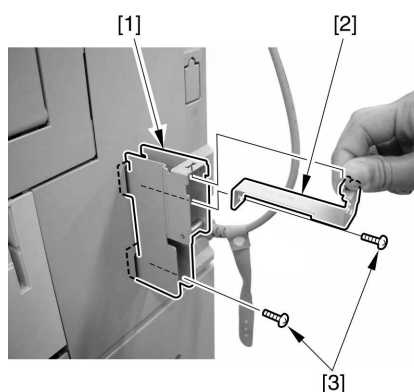

F-3-6

- 8) Attach the connect stay [1] to the cassette pedestal with the 5 screws (M4X33) [2] included in the package.

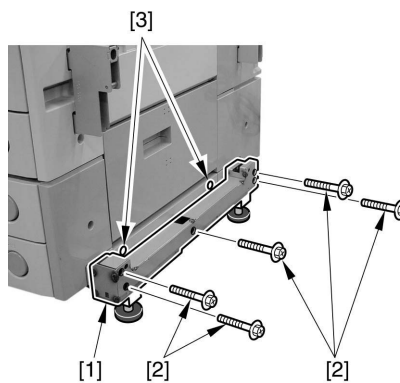

F-3-7

-
- ⚠** If it is hard to tighten a screw to the connect stay, loosen the 2 fixing screws [3] on the cover, and then attach the connect stay; after that, tighten back the fixing screws.
-

- 9) Rotate the adjusters (from and rear) [1] to secure them in place.
-

- ⚠** There is a possibility of malfunction if the adjusters are improperly adjusted. Be sure to contact the adjusters on the floor.
-

- 10) Remove the 2 screws [3] of the bottom stay

extension plate [2] found on the deck mount [1], and shift the position of the plate to the groove marked "F"; secure the plate in place with the 2 screws. (Perform both of the front and rear extension plates)

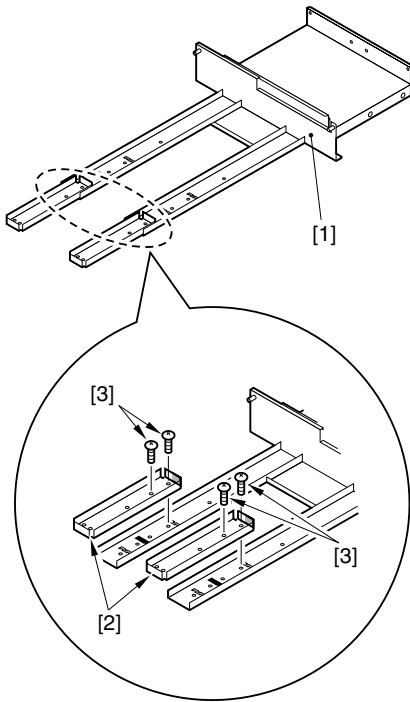

F-3-8

11) Remove the screw [1], and detach the stopper [2] of the deck mount.

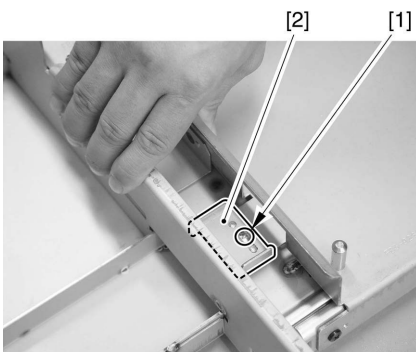

F-3-9

⚠To prevent an unintentional slide of the deck mount, hold the 2 plates facing the deck mount with your hand when removing the stopper

12) Turn over the detached stopper [2], and tighten the screw to the same hole to secure it [1] in place.

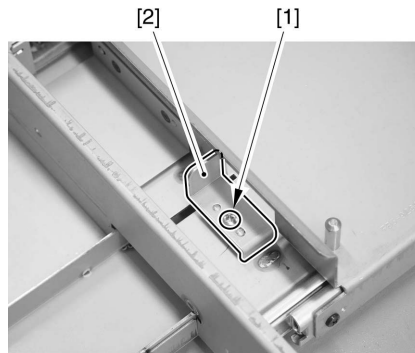

F-3-10

13) From the right side of the host machine, slide the deck mount [1] under the host. After that, insert the pins of the deck mount into the 2 holes of the connect stay while lifting up the right side of the deck mount slightly.

14) Secure the deck mount to the host machine with the 3 screws (M4x6) [2] included in the package.

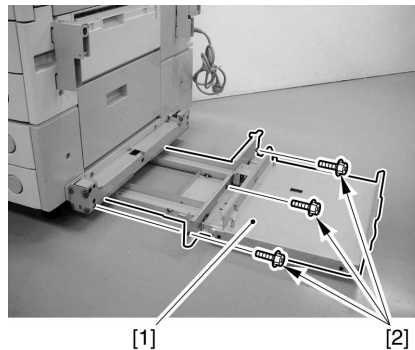

F-3-11

15) Attach the 2 fixing hardware [1] and mount protection cover [2] to the deck mount using one screw each (M4x6) [3]; secure the upper face of the fixing hardware to the host machine with the screw (M4x6) [3] included in the package.

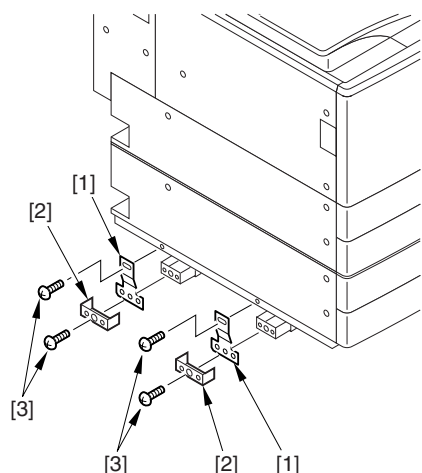

F-3-12

- 16) Slide out the deck mount [1] to the right direction (away from the host machine) with your hand.
 17) Place the cushioning materials [2] included in the package next to the deck mount.

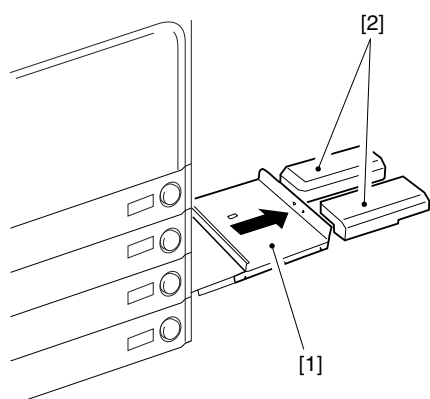

F-3-13

- 18) Remove the plastic wrapping [1] covering the paper deck Q1; hold the positions specified in the fig. below, and place the machine onto the cushioning materials prepared at step 17).

- ⚠** 1. The area [2] shown in Fig. below may be deformed; therefore, be sure not to hold the area.
 2. When lifting up the machine, be sure to hold the part where the grip indication labels [3] are attached and to lift it up with a group of 2 or more people.

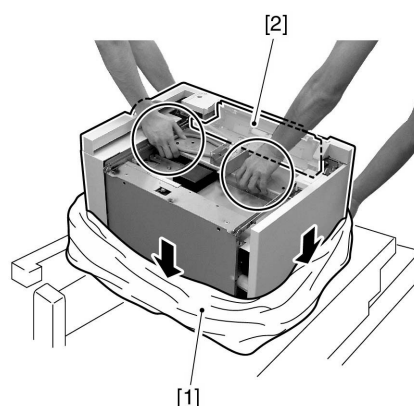

F-3-14

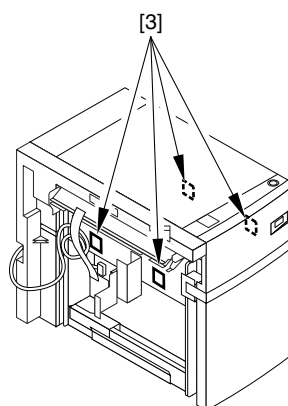

F-3-15

- 19) Remove the fixing material [1] from the machine.

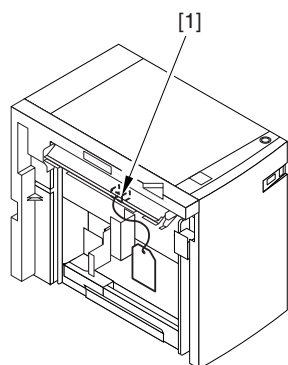

F-3-16

- 20) Remove the 3 screws [1] mounting on the right side. The detached 3 screws will be used at step 32).

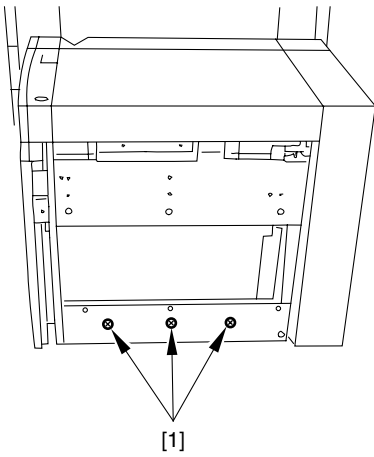

F-3-17

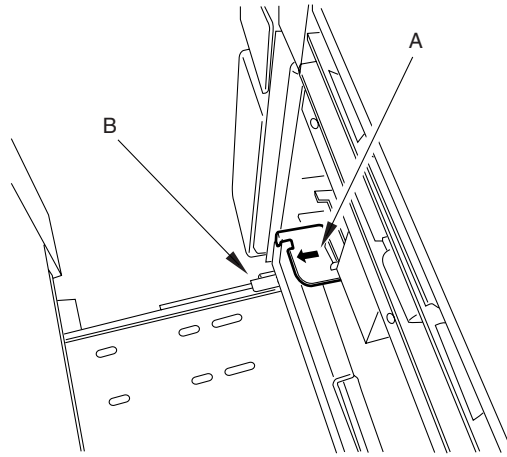

F-3-19

21) Hold the positions (i.e., grip indication label areas) specified in the fig. below, and place the machine onto the deck mount by matching the machine's holes [1] to the pins [2] of the deck mount. For ease of attachment, match the arrow (A) of the lower left stay to the edge (B) of the deck mount at this time.

22) Secure the machine to the deck mount with the 4 screws (M4x6) [1] included in the package.

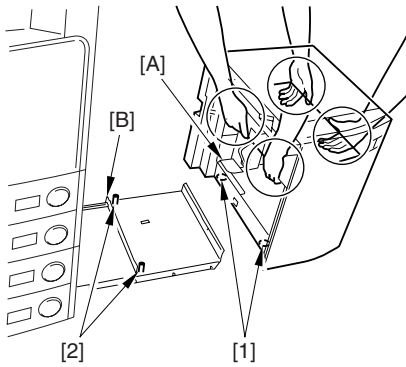

F-3-18

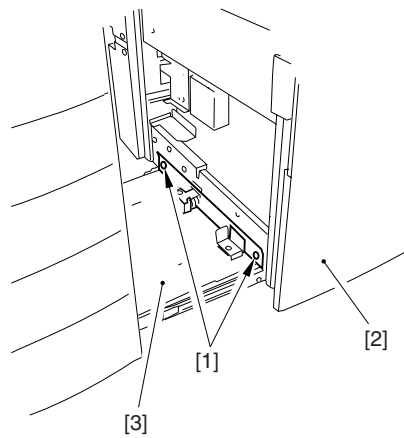

F-3-20

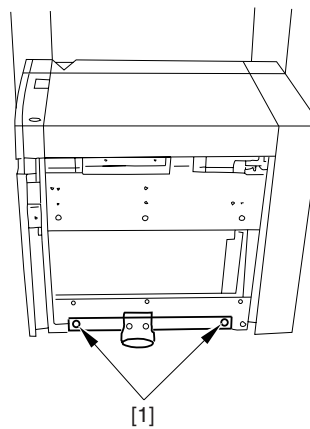

F-3-21

23) To open the housing unit [2] of the machine, push down the latch plate [1] found at the housing unit.

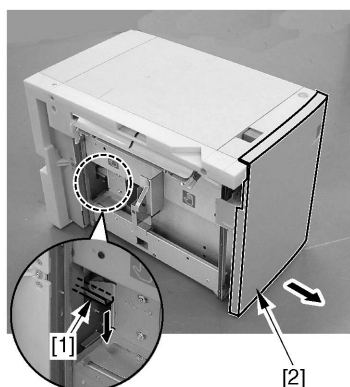

F-3-22

24) Detach the 4 screws [1], and remove the fixing material [2] and cushioning material [3] placed inside the housing unit. The fixing material will not be used, but the detached 4 screws will be used at step 30).

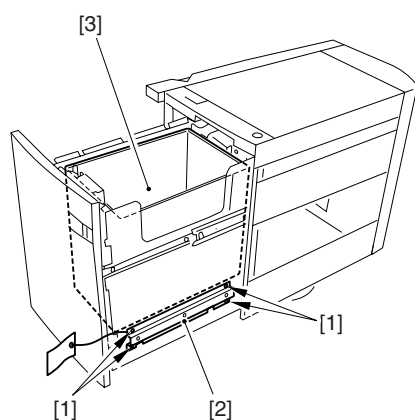

F-3-23

25) Remove the 4 grip indication labels [1] placed on the machine.

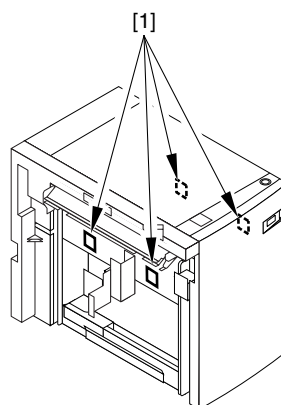

F-3-24

26) Attach the slope guide (Upper) [1] with the screw (M4x6) [2] included in the package.

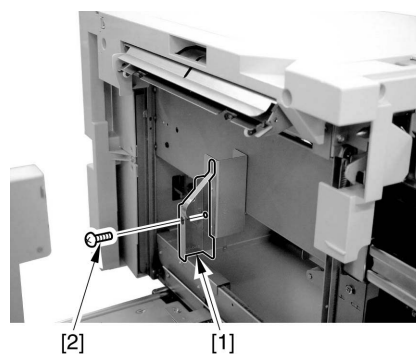

F-3-25

27) Refer to a scale marking around the mounting screw [1], and keep the mounting position of the front cover in mind.

28) Loosen the 4 screws, and detach the front cover [2] to the front direction.

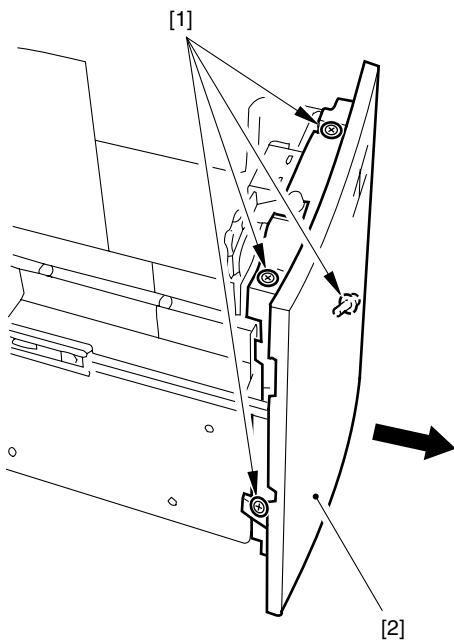

F-3-26

- 29) Attach the paper deck unit to the host machine.
- 30) Secure the roller support plate [2] with the 4 screws [3] detached at step 24) so that the width A (between the roller [1] and the floor) is set to approx.3mm with the housing unit opened.

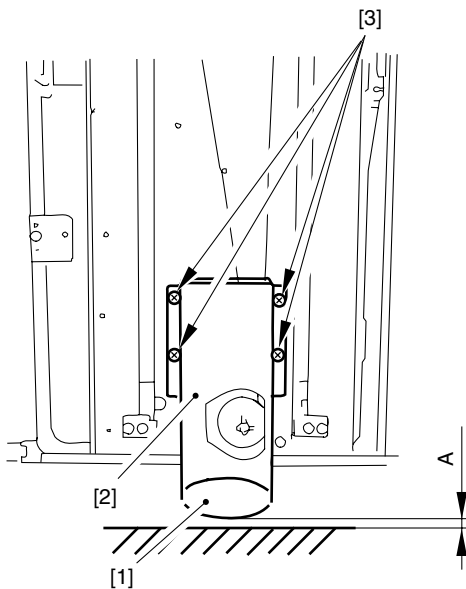

F-3-27

- 31) Attach the front cover [1].
- 32) Attach the right cover with the 3 screws [2]

- detached at step 20).
- 33) Slide out the compartment.

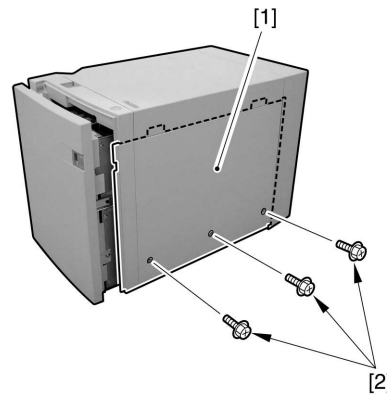

F-3-28

⚠ Be sure to disconnect the power plug of the host machine.

- 34) Peel off the face sticker [1] of the host machine.

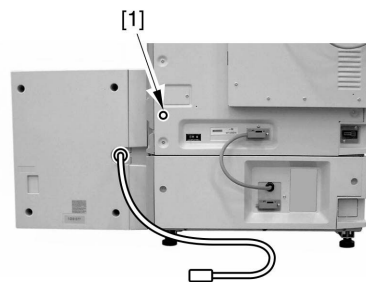

F-3-29

- 35) Remove the connector cover at the rear of the cassette pedestal, and connect the connector of the machine.
- 36) Fit the included wire saddle [2]; then, fix the cable in place using the saddle.

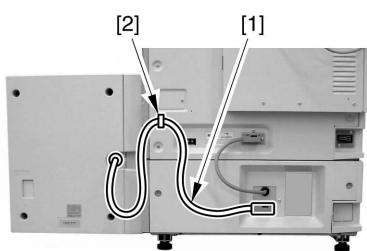

F-3-30

37) Confirm a user's request, and attach the paper size label [1] and open label [2] to the front cover [3].

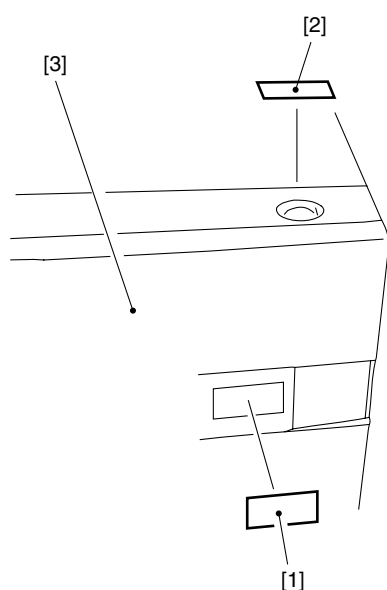

F-3-31

38) Detach the deck from the host machine; then, mount the deck right front cover [1] using the included screw (M4x6) [2]. Fit the claw [3] of the bottom of the cover on the connector stay; then, fix it in place using a screw.

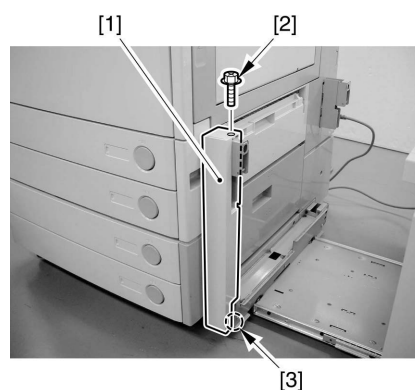

F-3-32

Perform the following steps 39) and 40) in case the paper size is A4.

39) Attach the deck to the host machine; then, turn on the host machine.

When the Release button of the deck has stopped flashing, press the deck compartment release button, and slide out the compartment.

40) Peel off the released paper [2] of the lifter plate sheet [1] included in the package, and attach the sheet to the lifter plate shown in the fig.

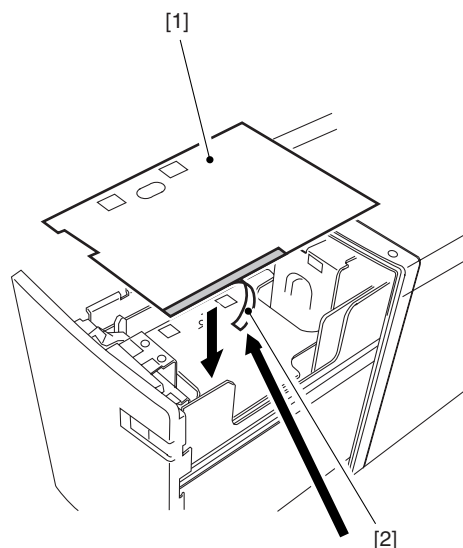

F-3-33

⚠ When attaching the lifter plate sheet, place the double-sided tape onto the lifter plate while pressing the lifter plate sheet [2] to A and B parts of

the rear separation sheet [1]. At this time, check to make sure that the lifter plate sheet does not run onto the separation sheet at the front side of the paper sensor's groove.

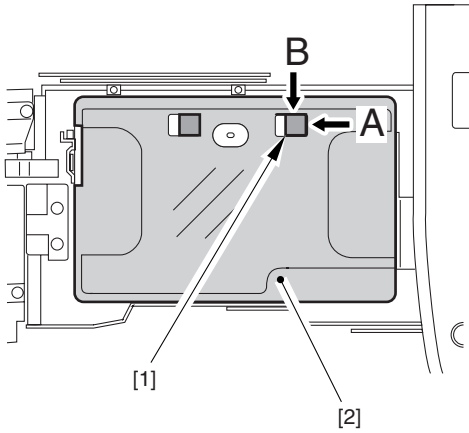

F-3-34

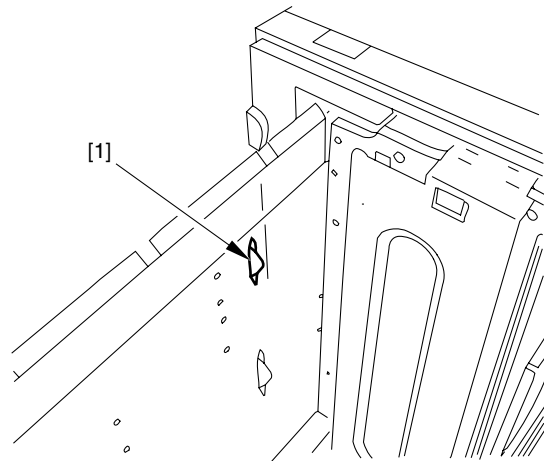

F-3-35

3) Remove the screw [1], and attach the paper end plate [2] by matching its mounting position to new paper size.

(The paper end plate is not used for the LTR size. The paper sizes are marked on the bottom plate.)

4) Likewise, remove the screw [3], and attach the end plates (right, left) [4] by matching their mounting positions to new paper size.

3.1.3 Making Adjustments

3.1.3.1 Switching the Paper

Size

0004-6771

- 1) Open the housing unit.
- 2) When the machine's lifter is upside, turn ON the power switch of the host machine, and push the sensor lever [1] of the loading paper positioning sensor found inside the housing unit; move down the lifter to its bottom level.

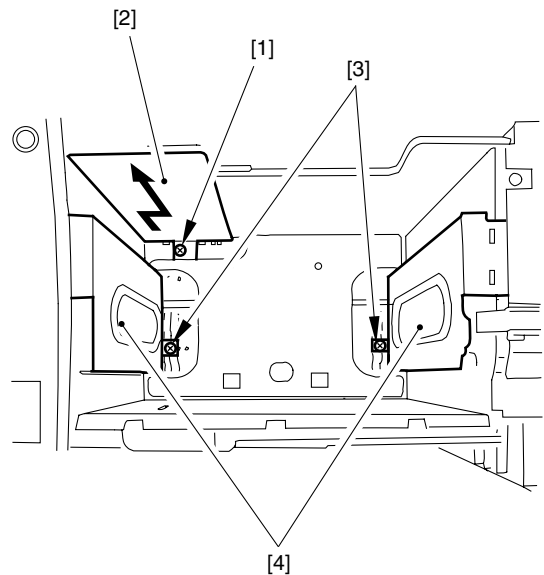

F-3-36

5) Set up service mode of the host machine (COPIER>OPTION>ACC>DK-P) to suit the paper size.

0:A4

2:LTR

▲ Be sure to turn OFF and ON the host machine after changing the setting.

3.1.3.2 Adjusting the Horizontal 0004-6789

1) Check to make sure that the 4 adjusters [1] of the host machine's pedestal are well contacted on the floor.

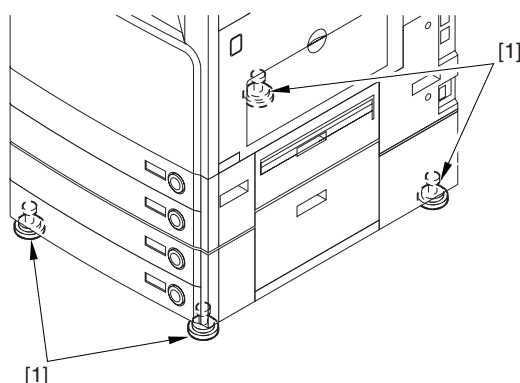

F-3-37

- 2) Connect the power plug of the host machine, and turn ON the power switch.
 - 3) After "WAIT" of the host machine is completed, perform a paper pick-up operation from the machine to check the operation.
 - 4) Make double-sided copy/print using the test image, and check to make sure that the blank (front side) from the image is within 2.5 +/-1.5 mm.
- Perform the following steps if the blank (front side) is out of 2.5 +/-1.5 mm.

3.1.3.3 A. Adjusting Horizontal Registration of the 1st Face 0004-6792 (Mechanical Adjustment)

1) Make a copy from the machine, and check to make sure that the blank (front side) is 2.5 +/-1.5 mm.

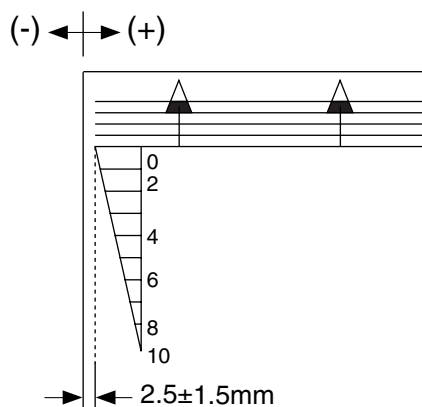

F-3-38

Perform the following adjustment if the horizontal registration is out of 2.5 +/-1.5 mm.

- 2) Pull out the housing unit.
(Refer to step 23))
- 3) Detach the deck from the host machine.
- 4) Adjust the mounting position of the latch support plate [1] of the deck open solenoid (SL2D) found at the rear left with the 2 screws [2].

▲ At this time, it is better to use the scale [3] of the latch support plate as a guide.

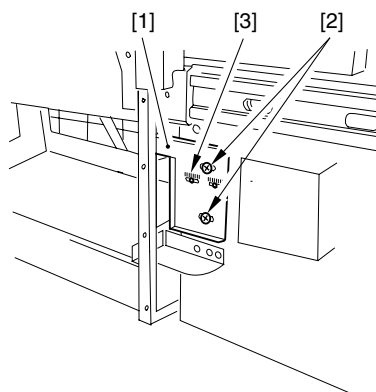

F-3-39

3.1.3.4 Adjusting Horizontal Registration of the Back Side Paper (2nd face) 0004-6795

1) Start service mode, and check the adjustment value

for the 2nd face horizontal registration of the cassette 1.

-COPIER> ADJUST> FEED-ADJ> ADJ-C1RE

2) Input the adjustment value for the 2nd face horizontal registration of the cassette 1 to the adjustment value for the 2nd face horizontal registration of the deck.

-COPIER> ADJUST> FEED-ADJ> ADJ-DKRE

3) Make a double-sided copy from the deck, and check to make sure that the blank (front side) is 2.5 ± 2 mm.

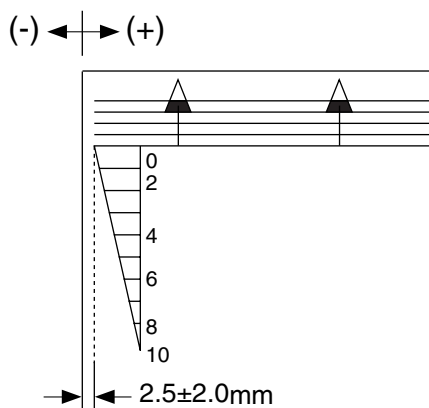

F-3-40

-If the deck is out of spec, perform the following adjustment.

4) Input new adjustment value to service mode.

-COPIER> ADJUST> FEED-ADJ> ADJ-DKRE

If the adjustment value is increased for 1, an image shifts to the paper feeding direction by 0.1 mm.

5) Press "RESET" twice to end service mode.

3.1.3.5 Adjusting the Mounting

Position of the Front Cover [0004-6815](#)

1) For the mounting position of the front cover [1], be sure to make a gap 3 ± 1 mm. between the front cover and front upper cover [2] when attaching.

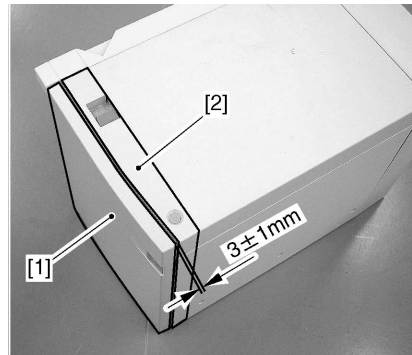

F-3-41

3.1.3.6 Adjusting the Side Roller Height [0004-6818](#)

Checking Before Adjustment

1) Detach the machine from the host machine, and attach it again to the host machine. At this time, check to see if the host machine does not shift/become unstable due to the attachment-shock.

If the host machine has shifted/become unstable by the shock, it is necessary to adjust the height of the side rollers. However, it is unnecessary if the above-mentioned symptom does not occur on the host machine.

Adjusting Procedure

- 1) Connect the machine to the host machine.
- 2) Take out papers from the deck if any.
- 3) Remove the right cover [1] of the machine.

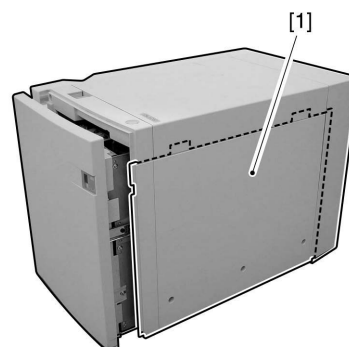

F-3-42

4) Loosen the 2 fixing screws [2] for the side roller [1].

- 5) Contact the side roller on the floor, and tighten the fixing screws. At this time, refer to the scale so that the right and left screws indicate the same point.

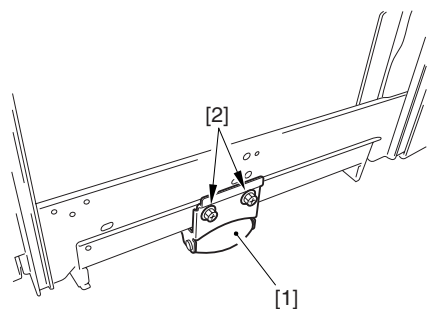

F-3-43

- 6) Detach the machine from the host machine, and attach it again to the host machine. If the required force to connect the machine does not increase, attach the right cover of the machine, and store papers in the deck to complete the work.
If the required force has increased, follow the steps below.
- 7) Check the scale positions of the side rollers.
- 8) Loosen the fixing screws of the side rollers.
- 9) Refer to the scale, and raise the side rollers by 1mm; tighten the fixing screws.
- 10) Attach the right cover, and store papers in the deck.

Chapter 4 Parts

Replacement Procedure

Contents

4.1 Removing from the Host Machine	4-1
4.1.1 Paper Deck-Q1	4-1
4.1.1.1 Preparing for the Detachment.....	4-1
4.1.1.2 Opening the Compartment	4-1
4.1.1.3 Removing the Right Cover.....	4-1
4.1.1.4 Detaching the Deck From Its Host Machine	4-2
4.2 Drive System	4-3
4.2.1 Deck Pickup Clutch.....	4-3
4.2.1.1 Removing the Left Rear Cover.....	4-3
4.2.1.2 Removing the Left Upper Cover	4-3
4.2.1.3 Removing the Rear Cover	4-3
4.2.1.4 Removing the Front Cover (upper)	4-3
4.2.1.5 Removing the Upper Cover.....	4-4
4.2.1.6 Removing the Deck Pickup Unit.....	4-4
4.2.1.7 Removing the Deck Pickup Clutch (CL2D).....	4-4
4.2.2 Deck Feed Clutch	4-4
4.2.2.1 Removing the Left Rear Cover.....	4-4
4.2.2.2 Removing the Left Upper Cover	4-5
4.2.2.3 Removing the Rear Cover	4-5
4.2.2.4 Removing the Front Cover (upper)	4-5
4.2.2.5 Removing the Upper Cover.....	4-5
4.2.2.6 Removing the Deck Feed Clutch (CL1D).....	4-6
4.2.3 Deck Main Motor	4-6
4.2.3.1 Removing the Left Rear Cover.....	4-6
4.2.3.2 Removing the Rear Cover	4-6
4.2.3.3 Removing the Deck Main Motor (M1D).....	4-6
4.2.4 Deck Lifter Motor	4-7
4.2.4.1 Opening the Compartment	4-7
4.2.4.2 Positioning the Deck Lifter	4-7
4.2.4.3 Removing the Compartment.....	4-7
4.2.4.4 Removing the Deck Lifter Motor (M2D).....	4-9
4.2.5 Lifter Cable (Front)	4-9
4.2.5.1 Opening the Compartment	4-9
4.2.5.2 Removing the Lifter Cable (deck front)	4-9
4.2.5.3 Routing the Lifter Cable.....	4-11
4.2.6 Lifter Cable.....	4-11
4.2.6.1 Opening the Compartment	4-11
4.2.6.2 Removing the Compartment.....	4-12
4.2.6.3 Removing the Lifter Cable (deck rear).....	4-13
4.2.6.4 Routing the Lifter Cable	4-14
4.3 Document Feeding System.....	4-16
4.3.1 Deck Pickup Unit	4-16
4.3.1.1 Removing the Left Rear Cover.....	4-16
4.3.1.2 Removing the Left Upper Cover	4-16

4.3.1.3 Removing the Rear Cover.....	4-16
4.3.1.4 Removing the Front Cover (upper).....	4-16
4.3.1.5 Removing the Upper Cover.....	4-17
4.3.1.6 Removing the Deck Pickup Unit.....	4-17
4.3.2 Deck Pickup Roller.....	4-17
4.3.2.1 Removing the Left Rear Cover.....	4-17
4.3.2.2 Removing the Left Upper Cover.....	4-17
4.3.2.3 Removing the Rear Cover.....	4-18
4.3.2.4 Removing the Front Cover (upper).....	4-18
4.3.2.5 Removing the Upper Cover.....	4-18
4.3.2.6 Removing the Deck Pickup Unit.....	4-18
4.3.2.7 Removing the Deck Pickup Roller.....	4-19
4.3.2.8 Points to Note When Mounting the Pickup Roller.....	4-19
4.3.3 Deck Pickup/Feed Roller.....	4-20
4.3.3.1 Removing the Left Rear Cover.....	4-20
4.3.3.2 Removing the Left Upper Cover.....	4-20
4.3.3.3 Removing the Rear Cover.....	4-20
4.3.3.4 Removing the Front Cover (upper).....	4-21
4.3.3.5 Removing the Upper Cover.....	4-21
4.3.3.6 Removing the Deck Pickup Unit.....	4-21
4.3.3.7 Removing the Deck Pickup/Feed Roller.....	4-22
4.3.3.8 Points to Note When Mounting the Deck Pickup/Feed Roller.....	4-22
4.3.4 Deck Separation Roller.....	4-22
4.3.4.1 Removing the Deck Separation Roller.....	4-22
4.4 Electrical System.....	4-24
4.4.1 Deck Driver PCB.....	4-24
4.4.1.1 Removing the Left Rear Cover.....	4-24
4.4.1.2 Removing the Rear Cover.....	4-24
4.4.1.3 Removing the Deck Driver PCB.....	4-24
4.4.2 Open Switch PCB.....	4-24
4.4.2.1 Opening the Compartment.....	4-24
4.4.2.2 Removing the Front Cover (upper).....	4-25
4.4.2.3 Removing the Open Switch PCB.....	4-25

4.1 Removing from the Host Machine

4.1.1 Paper Deck-Q1

4.1.1.1 Preparing for the Detachment 0002-7736

- 1) To prevent deformation of the roll support plate [1], place a stack of paper [3] (A; about 8 cm) on the floor to prepare for the placement of the deck [2].

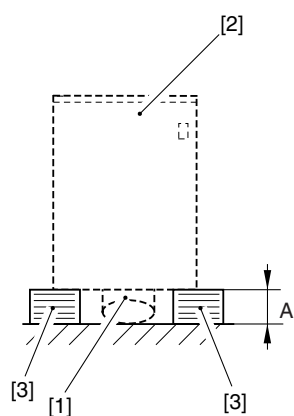

F-4-1

4.1.1.2 Opening the Compartment 0002-7625

- 1) Push the deck release grip [1] to free the deck from its host machine; then, push down the latch plate [2] found at the left rear to open the compartment.

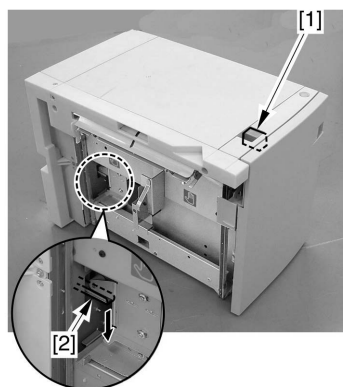

F-4-2

4.1.1.3 Removing the Right Cover 0002-7779

- 1) Remove the 3 screws [1], and shift down the right cover [2]; then, detach it to the front.

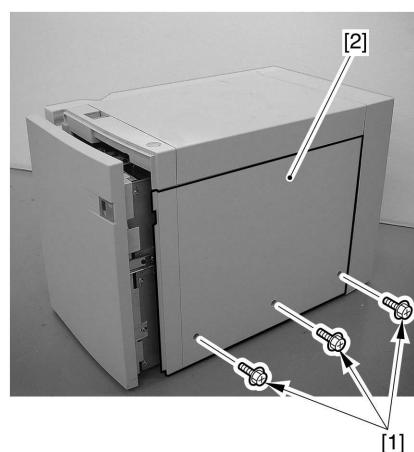

F-4-3

Reference

When mounting the right cover, fit the claw [1] on the top of the right cover in the slot [2] of the paper deck stay; then, fit the right edge of the right cover [3] inside of the rear cover [4].

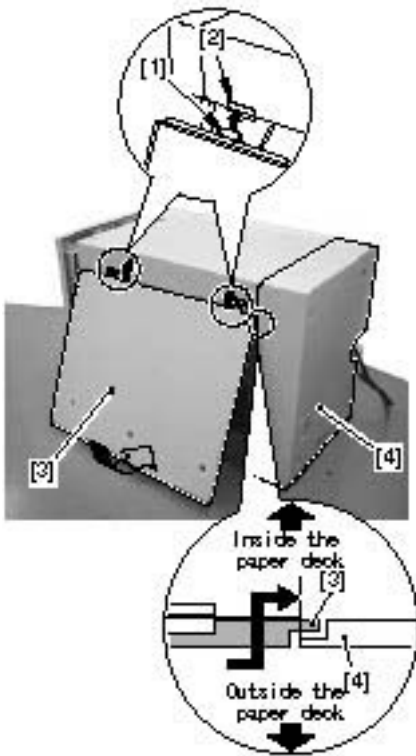

F-4-4

4.1.1.4 Detaching the Deck

From Its Host Machine

[0002-7797](#)

1) Remove the 2 screws [1] found on the right side.

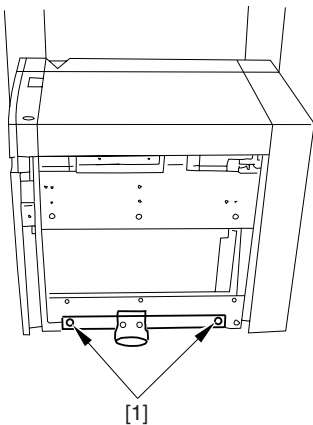

F-4-5

2) Remove the 2 screws from the left side, and detach the deck [2] from the deck base [3].

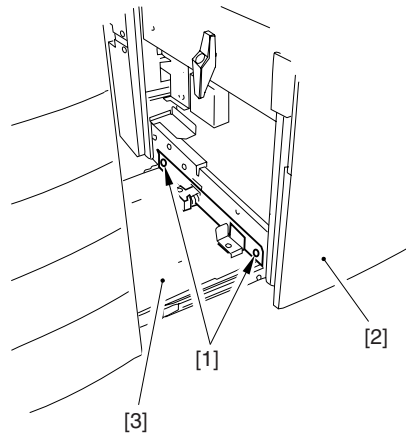

F-4-6

3) Hold the deck [1] with your hands at the locations indicated with circles, and place it on the stack of paper you have previously prepared.

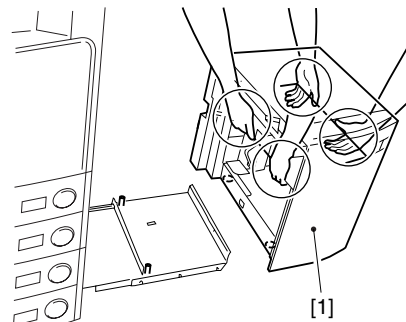

F-4-7

4.2 Drive System

4.2.1 Deck Pickup Clutch

4.2.1.1 Removing the Left Rear

Cover

0001-1181

- 1) Free the deck from its host machine.
- 2) Remove the 2 screws [1] and 2 self-tapping screws [3]; then, detach the left rear cover [2].

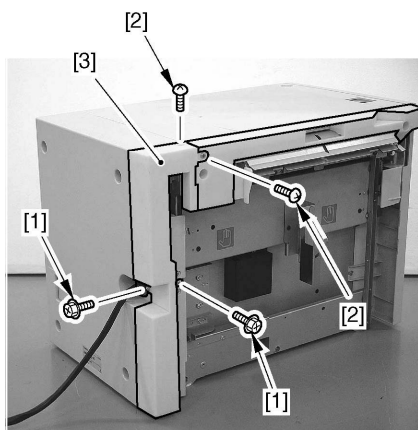

F-4-8

4.2.1.2 Removing the Left Upper Cover

0001-1185

- 1) Remove the 2 screws [1], and detach the left upper cover.

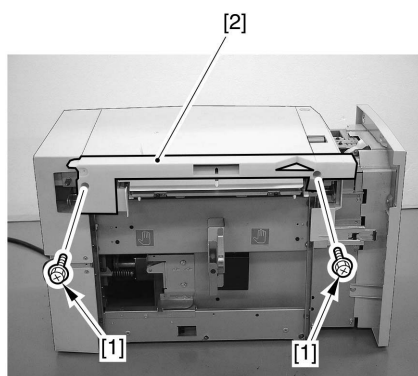

F-4-9

4.2.1.3 Removing the Rear Cover

0001-1430

- 1) Remove the 2 binding screws [1] and the 4 RS tightening screws [3]; then, detach the rear cover [2].

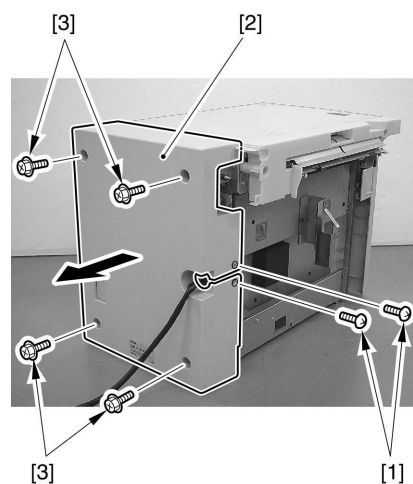

F-4-10

4.2.1.4 Removing the Front Cover (upper)

0001-1445

- 1) Remove the 3 screws [1], and disconnect the connector; then, detach the front cover (upper) [3].

⚠ When mounting the front cover (upper), be sure that the harness to the open switch PCB is not trapped and all connectors are properly connected.

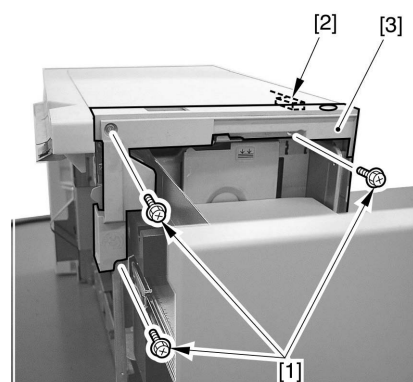

F-4-11

4.2.1.5 Removing the Upper Cover

0001-1198

- 1) Remove the 2 screws [1], and detach the upper cover [2].

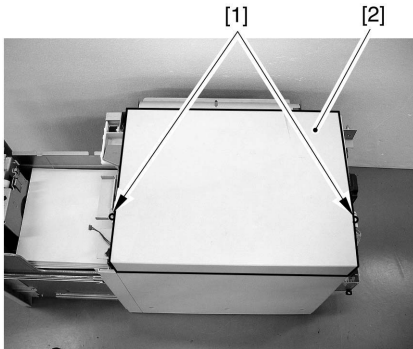

F-4-12

4.2.1.6 Removing the Deck Pickup Unit

0001-1417

- 1) Detach the deck release grip [1] in upward direction.
- 2) Disconnect the 2 connectors [2], and remove the 5 screws [3].
- 3) Detach the pickup harness [4].
- 4) Remove the deck pickup unit [5].

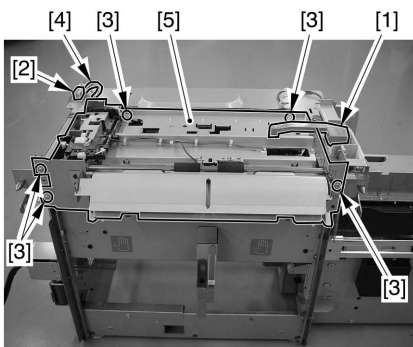

F-4-13

⚠ When mounting the deck pickup unit [1], tighten

the 3 screws [2] first and then the remaining 2 screws [3].

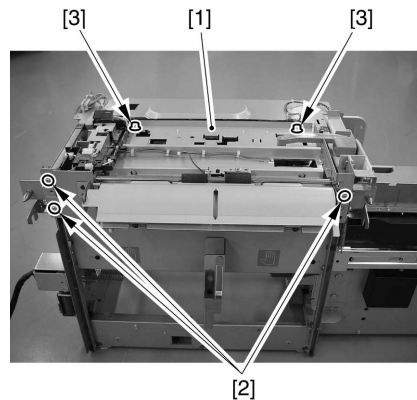

F-4-14

4.2.1.7 Removing the Deck Pickup Clutch (CL2D)

0001-1201

- 1) Disconnect the connector [1], and remove the E-ring [2]; then, detach the deck pickup clutch [3].

⚠ When mounting the deck pickup clutch, be sure that the clutch is fitted to the stop [4]. Also, be sure that the harness is fitted to the U-groove [5] of the guide.

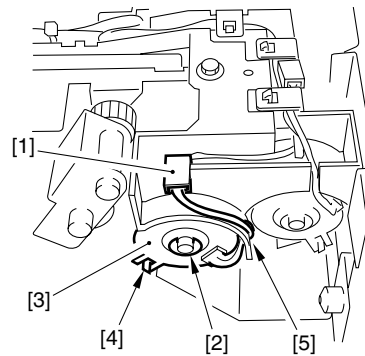

F-4-15

4.2.2 Deck Feed Clutch

4.2.2.1 Removing the Left Rear Cover

0002-4927

- 1) Free the deck from its host machine.
- 2) Remove the 2 screws [1] and 2 self-tapping screws

[3]; then, detach the left rear cover [3].

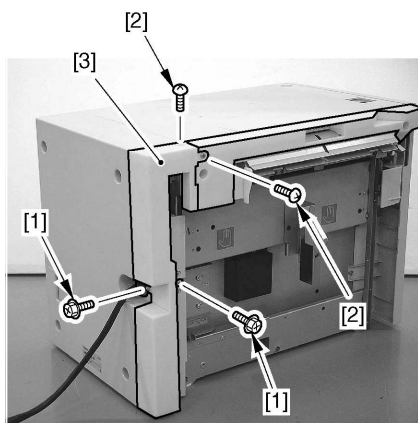

F-4-16

4.2.2.2 Removing the Left Upper Cover

[0002-4934](#)

- 1) Remove the 2 screws [1], and detach the left upper cover.

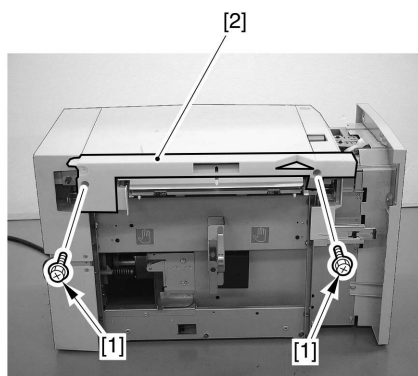

F-4-17

4.2.2.3 Removing the Rear Cover

[0002-4939](#)

- 1) Remove the 2 binding screws [1] and the 4 RS tightening screws [3]; then, detach the rear cover [2].

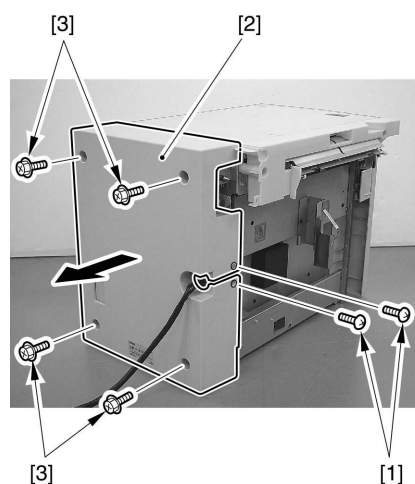

F-4-18

4.2.2.4 Removing the Front Cover (upper)

[0002-4951](#)

- 1) Remove the 3 screws [1], and disconnect the connector; then, detach the front cover (upper) [3].

⚠ When mounting the front cover (upper), be sure that the harness to the open switch PCB is not trapped and all connectors are properly connected.

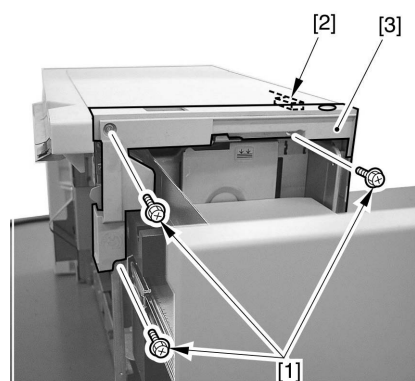

F-4-19

4.2.2.5 Removing the Upper Cover

[0002-4956](#)

- 1) Remove the 2 screws [1], and detach the upper cover [2].

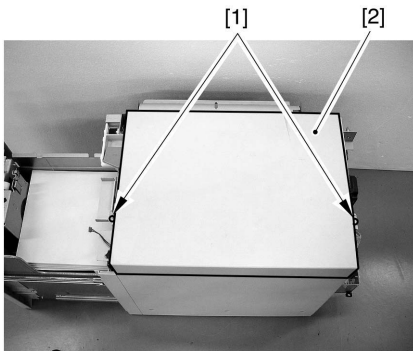

F-4-20

4.2.2.6 Removing the Deck

Feed Clutch (CL1D) 0001-1205

- 1) Remove the harness retainer [1], disconnect the connector [2], and remove the E-ring [3]; then, detach the deck feed clutch [4].

⚠ When mounting the deck feed clutch, be sure that the clutch is fitted in the stop

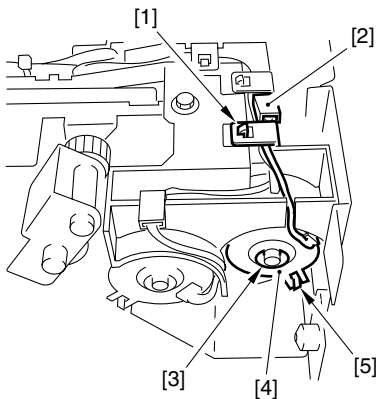

F-4-21

4.2.3 Deck Main Motor

4.2.3.1 Removing the Left Rear Cover 0002-4928

- 1) Free the deck from its host machine.
- 2) Remove the 2 screws [1] and 2 self-tapping screws

[3]; then, detach the left rear cover [3].

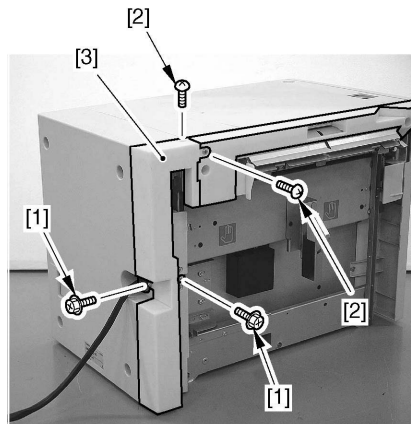

F-4-22

4.2.3.2 Removing the Rear Cover 0002-4944

- 1) Remove the 2 binding screws [1] and the 4 RS tightening screws [3]; then, detach the rear cover [2].

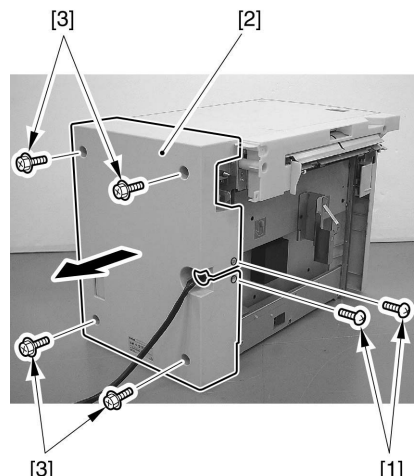

F-4-23

4.2.3.3 Removing the Deck Main Motor (M1D) 0001-1207

- ⚠** Disconnect the connector [1], and remove the 2 screws [2]; then, detach the deck main motor [3]. At this time, take care not to damage the gear found at the tip of the motor spindle.

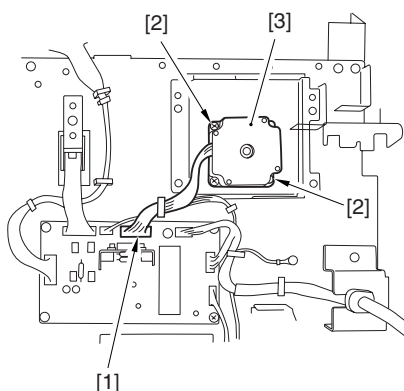

F-4-24

4.2.4 Deck Lifter Motor

4.2.4.1 Opening the Compartment

0002-4923

- 1) Push the deck release grip [1] to free the deck from its host machine; then, push down the latch plate [2] found at the left rear to open the compartment.

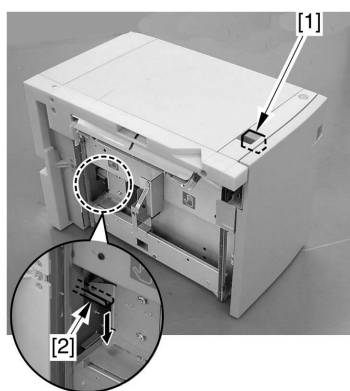

F-4-25

4.2.4.2 Positioning the Deck Lifter

0001-1186

- 1) If there is any paper, remove all of it.
- 2) If the deck lifter [1] is in up position, move it so that distance A from the base plate of the compartment of the deck is about 7 cm.

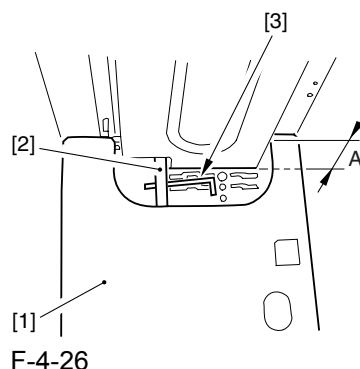

F-4-26

- 3) Connect the power plug, and turn on the host machine.
- 4) Push the sensor flag [2] of the paper supply position sensor found inside the compartment [1] so that the deck lifter moves down. (The deck lifter will stop as soon as you release the flag.)

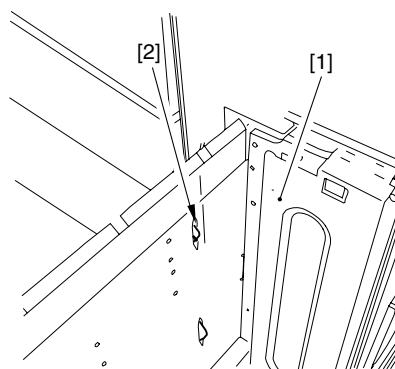

F-4-27

- 5) Insert a hex wrench [3] into the hole of the lifter drive shaft [2] so that it serves to keep the spindle from turning.
- 6) Disconnect the power plug.

4.2.4.3 Removing the Compartment

0001-1373

- 1) To prevent deformation of the roll support plate [1], place a stack of paper [3] (A: about 8 cm) on the floor for the placement of the deck [2].

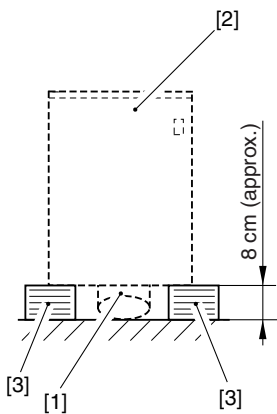

F-4-28

- 2) Remove the 3 screws [1], and shift down the right cover [2], then, detach it toward the front.

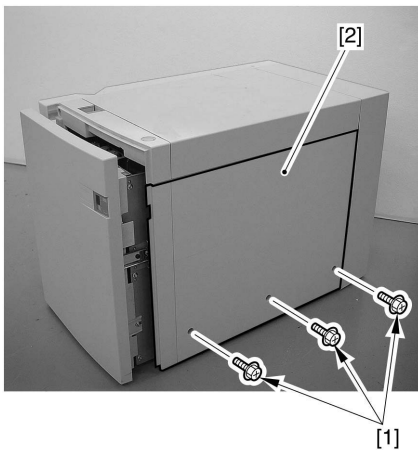

F-4-29

Reference:

When mounting the right cover, be sure that the claw [1] on the top of the right cover is in the hole [2] of the paper deck stay and the right edge [3] is inside the rear cover [4].

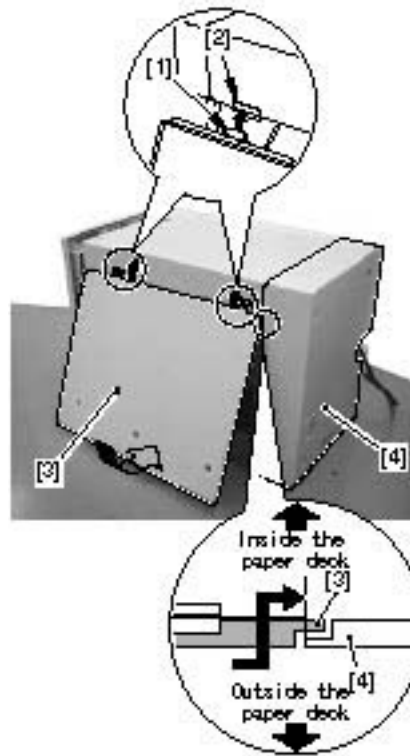

F-4-30

- 3) Disconnect the connector [1] found at the rear of the compartment, and remove the screw [2]; then, detach the harness unit [3].

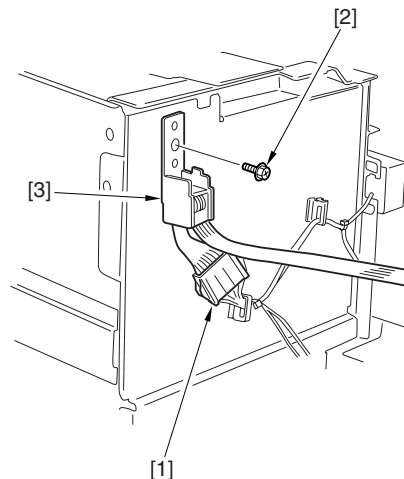

F-4-31

- 4) Remove the screw [1] and the stopper plate [2] found at the left rear of the deck; then, slide the compartment [3] farther out to the front.

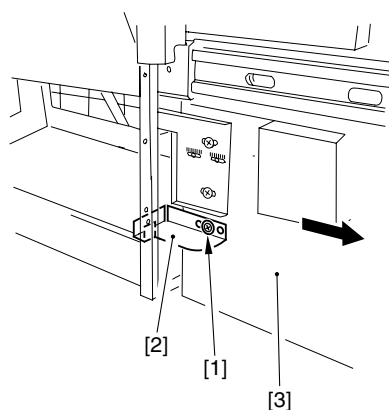

F-4-32

- 5) Remove the 3 screws [2] each from the left/right of the compartment rail [1]; then, lift the compartment [3] about 1 cm, and detach it to the front.
 - 6) Place the compartment [3] on the stack of paper you have previously prepared.
- Be sure to use the stack of paper to prevent deformation of the roll support plate.

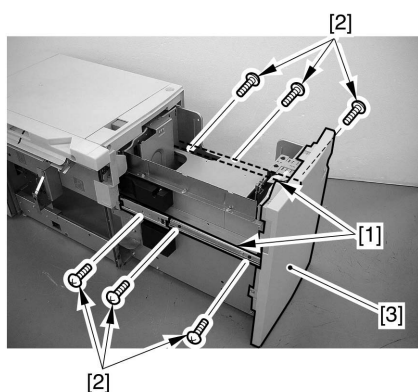

F-4-33

4.2.4.4 Removing the Deck Lifter Motor (M2D) 0001-1208

- 1) Disconnect the connector [1], and remove the 5 screws [2]; then, detach the deck lifter motor unit [3].

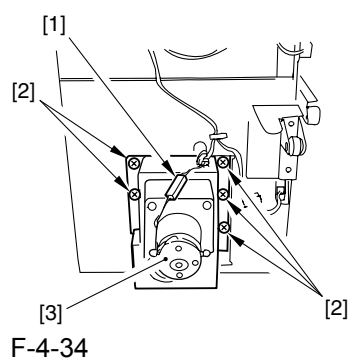

F-4-34

4.2.5 Lifter Cable (Front)

4.2.5.1 Opening the Compartment 0002-4925

- 1) Push the deck release grip [1] to free the deck from its host machine; then, push down the latch plate [2] found at the left rear to open the compartment.

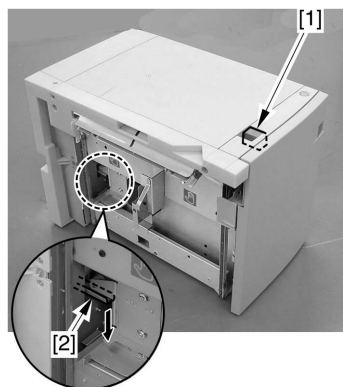

F-4-35

4.2.5.2 Removing the Lifter Cable (deck front) 0001-1210

- 1) If there is any paper, remove all of it.
 - 2) Insert 2 long screwdrivers [3] to keep the lifter in place.
 - 3) Push down the sensor flag [1] of the paper supply position sensor so that the lifter will move down, thus matching the left/right hole in the lifter and the left/right hole in the side plate of the compartment.
- Connect the power plug, and turn on the host

machine.

- Push the sensor flag [2] of the paper supply position so that the deck lifter will move down to reach the screwdrivers. (The deck lifter will stop as soon as you release the flag.)

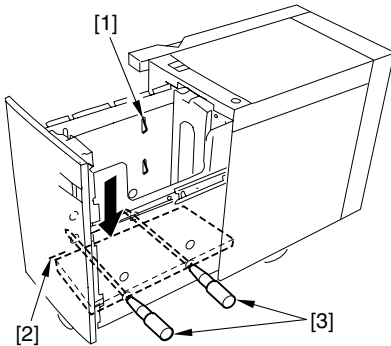

F-4-36

- 4) Loosen the 4 screws [1], and detach the front cover [2] to the front. Do not remove the screws.

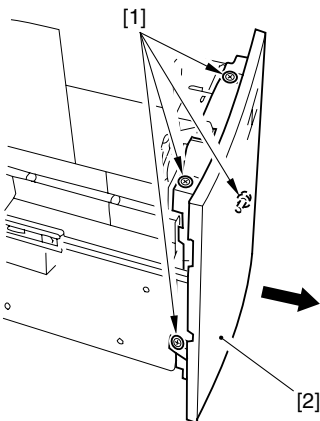

F-4-37

⚠ Be sure to adjust the position of the front cover using the 4 screws fitted to it so that the gap A between the front cover [1] and the front cover (upper) [2] is 3 +1, -1 mm.

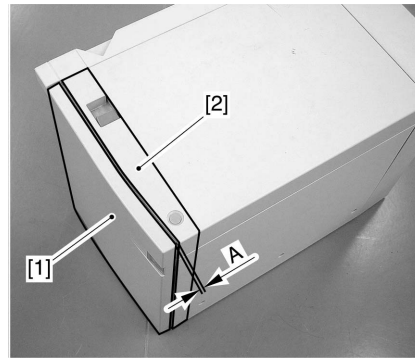

F-4-38

- 5) Remove the 4 screws [1] and detach the roll support plate [2].

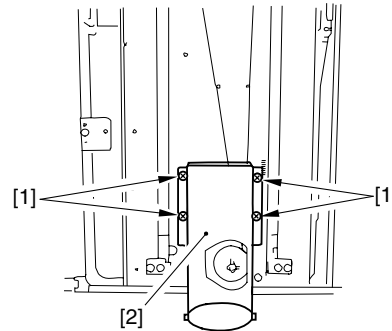

F-4-39

- 6) Remove the E-ring [2], and detach the pulley cover [3].
- 7) Remove the 2 screws [4] and the cable fixing plate [5] found on the left side; then, detach the lifter cable [6].
- 8) Remove the 2 screws [7] and the cable fixing plate [8] found on the right side; then, detach the lifter cable [9].
- 9) Detach the inside lifter cable [9] from the inside pulley [1] by removing the 2 set screws [12] and then the outside pulley [11].

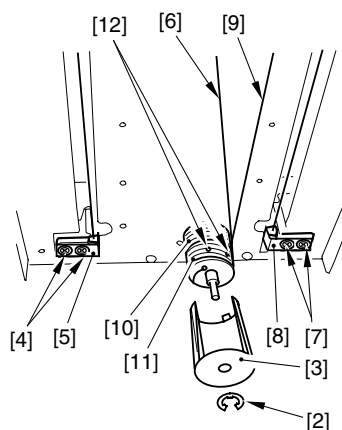

F-4-40

⚠ When mounting the pulley cover, be sure to match the claw [A] against the hole in the front side plate of the compartment.

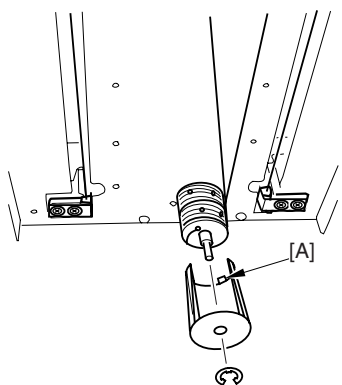

F-4-41

4.2.5.3 Routing the Lifter Cable 0002-4963

- 1) Check to be sure that the lifter driver shaft [1] and the lifter [2] are fixed in place by the 2 hex screwdrivers [4] and a hex wrench [3] or the like.
- 2) Secure the 4 cable fixing plates [5] in place to the lifter using 2 screws each.
- 3) Hook the lifter cable [6] on the 4 pulleys [7].
- 4) Hook the ball of the lifter cable on the 2 pulleys found at the front/rear of the lifter drive shaft; then, wind the cable about 1.5 times along the groove of the pulley.

At this time, see to it that the lifter cable is taut just

enough to lift the long screwdrivers used to keep the lifter in place.

- 5) Secure the 2 pulleys [5] in place to the lifter drive shaft using a set screw [9] (1 each).
- 6) After mounting all pulleys you have removed to the lifter drive shaft, measure the height A from the base plate of the compartment to the top surface of the lifter at several points, thereby making sure that the lifter is level.

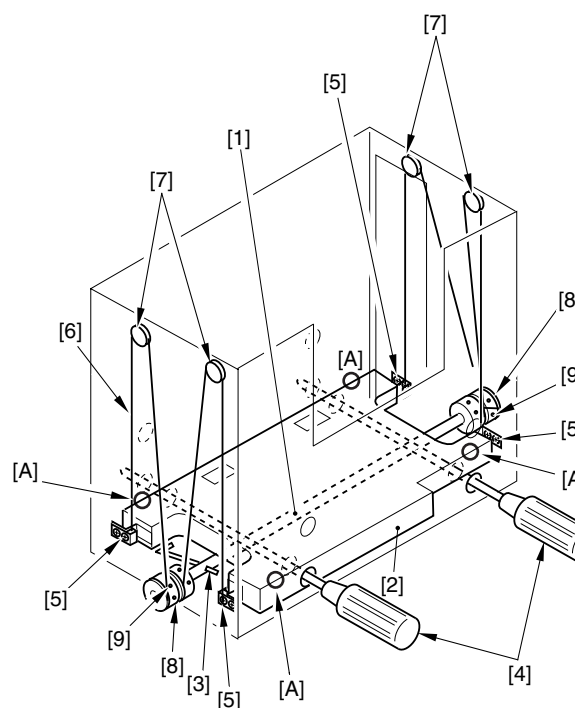

F-4-42

4.2.6 Lifter Cable

4.2.6.1 Opening the Compartment 0002-4926

- 1) Push the deck release grip [1] to free the deck from its host machine; then, push down the latch plate [2] found at the left rear to open the compartment.

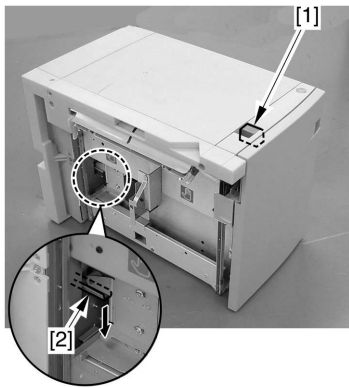

F-4-43

4.2.6.2 Removing the Compartment

0001-1498

- 1) If there is any paper, remove all of it.
- 2) Remove the screw [2], and detach the paper trailing edge guide plate [1] found inside the compartment. If the compartment is set to LTR as its paper size, it does not come fitted with the paper trailing edge guide plate.

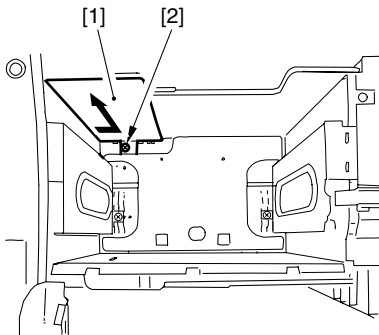

F-4-44

- 3) To prevent deformation of the roll support plate [1], place a stack of paper [3] (A: about 8 cm) on the floor for placement of the deck [2].

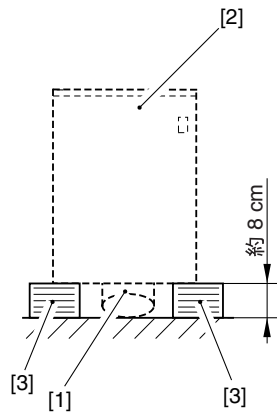

F-4-45

- 4) Remove the 3 screws [1], and shift the right cover [2] down and then to the front to detach.

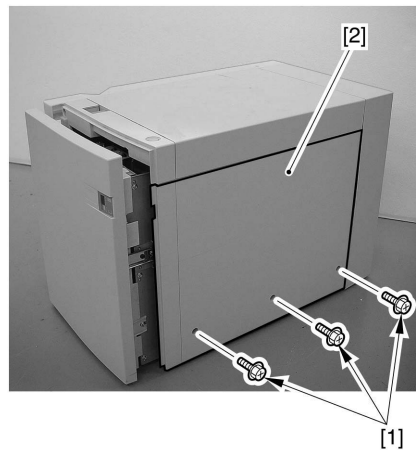

F-4-46

Reference:

When mounting the right cover, fit the claw [1] found at the top of the right cover into the hole [2] in the paper deck stay; then, fit the right edge [3] under the cover.

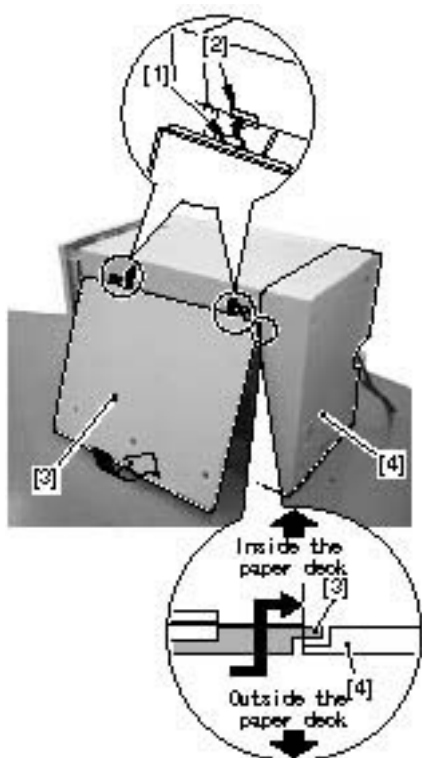

F-4-47

- 5) Disconnect the connector [1] and the screw [2] found at the rear of the compartment; then, detach the harness unit [3].

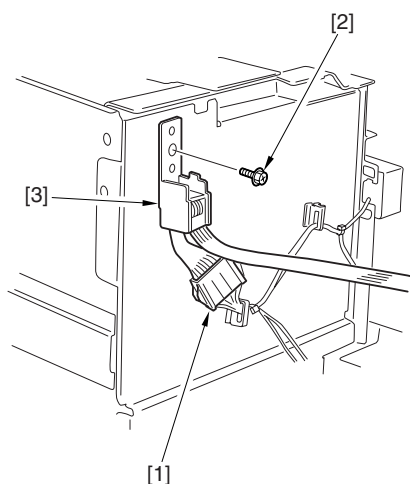

F-4-48

- 6) Remove the screw [1] and the stopper plate [2] from the left rear of the deck; then, slide out the compartment [3] to the front.

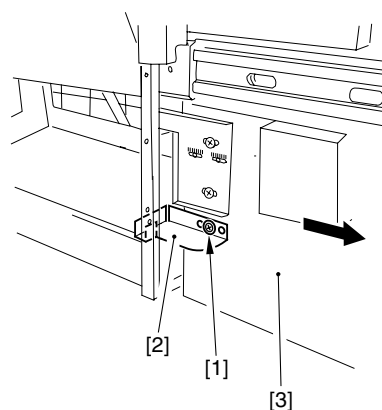

F-4-49

- 7) Remove the left and right screws [2] (3 pc. each) of the compartment rail [1]; then, lift the compartment [3] about 1 cm, and detach it to the front.
- 8) Place the compartment [3] on the stack of paper you prepared previously.
- (Be sure to place it on the stack of paper to avoid deformation of the roll support.)

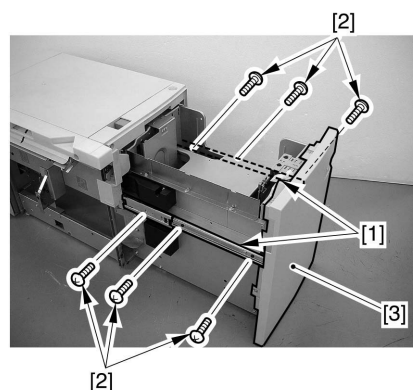

F-4-50

4.2.6.3 Removing the Lifter Cable (deck rear)

0001-1211

- 1) Remove the screw [1], and detach the upper sensor cover [2] and the lower sensor cover [3].
- 2) Disconnect the 4 connectors [4].

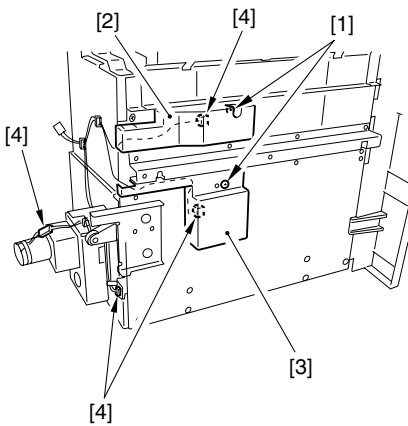

F-4-51

⚠ There are 2 claws on the top of the sensor cover; be sure to take care not to break them when removing the cover.

3) Remove the 5 screws [3], and detach the plate [4].

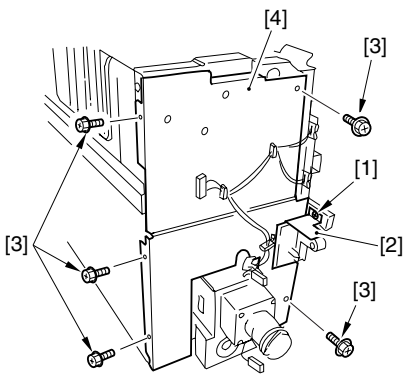

F-4-52

4) Insert a hex wrench [2] or the like into the hole of the lifter drive shaft [1] to keep it from turning.

⚠ If you fail to perform this step, the lifter cable will become slack as soon as you remove the lifter motor unit.

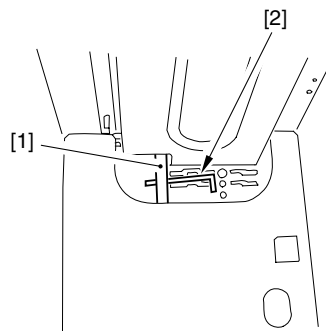

F-4-53

5) Remove the 5 screws [1], and detach the lifter motor unit [2].

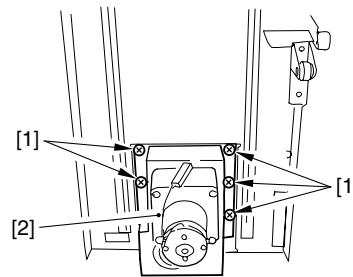

F-4-54

4.2.6.4 Routing the Lifter Cable 0001-1261

1) Check to be sure that the lifter driver shaft [1] and the lifter [2] are fixed in place by the 2 hex screwdrivers [4] and a hex wrench [3] or the like.

2) Secure the 4 cable fixing plates [5] in place to the lifter using 2 screws each.

3) Hook the lifter cable [6] on the 4 pulleys [7].

4) Hook the ball of the lifter cable on the 2 pulleys found at the front/rear of the lifter drive shaft; then, wind the cable about 1.5 times along the groove of the pulley.

At this time, see to it that the lifter cable is taut just enough to lift the long screwdrivers used to keep the lifter in place.

5) Secure the 2 pulleys [5] in place to the lifer drive shaft using a set screw [9] (1 each).

6) After mounting all pulleys you have removed to the lifter drive shaft, measure the height A from the base plate of the compartment to the top surface of

the lifter at several points, thereby making sure that the lifter is level.

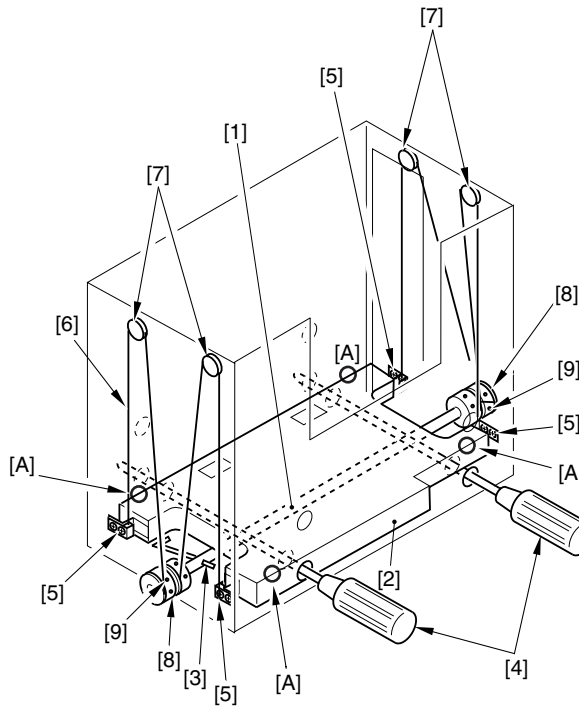

F-4-55

4.3 Document Feeding System

4.3.1 Deck Pickup Unit

4.3.1.1 Removing the Left Rear Cover

0002-4929

- 1) Free the deck from its host machine.
- 2) Remove the 2 screws [1] and 2 self-tapping screws [3]; then, detach the left rear cover [2].

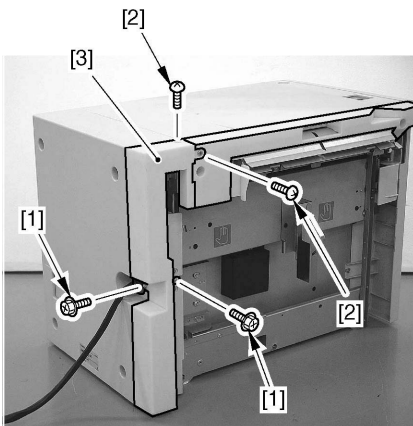

F-4-56

4.3.1.2 Removing the Left Upper Cover

0002-4935

- 1) Remove the 2 screws [1], and detach the left upper cover.

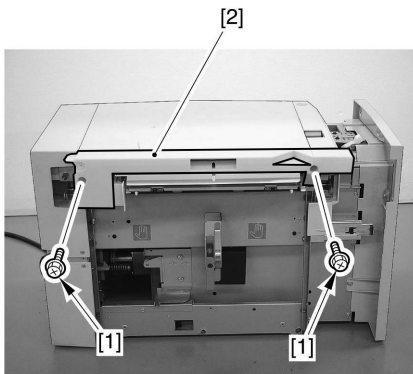

F-4-57

4.3.1.3 Removing the Rear Cover

0002-4945

- 1) Remove the 2 binding screws [1] and the 4 RS tightening screws [3]; then, detach the rear cover [2].

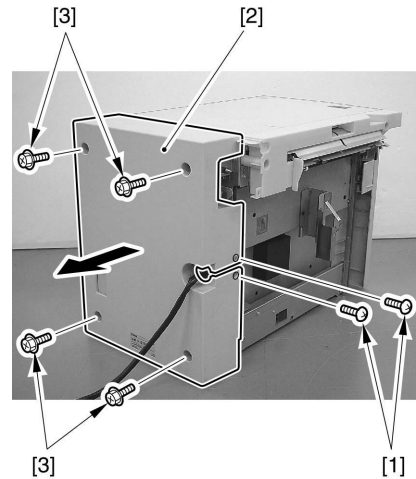

F-4-58

4.3.1.4 Removing the Front Cover (upper)

0002-4952

- 1) Remove the 3 screws [1], and disconnect the connector; then, detach the front cover (upper) [3].

⚠ When mounting the front cover (upper), be sure that the harness to the open switch PCB is not trapped and all connectors are properly connected.

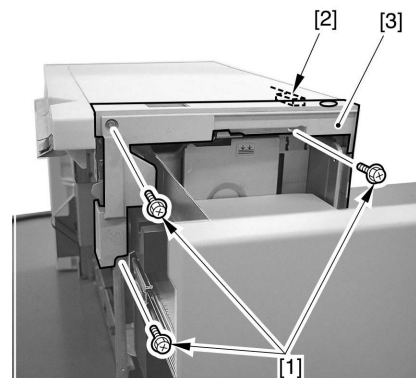

F-4-59

4.3.1.5 Removing the Upper Cover

0002-4957

- 1) Remove the 2 screws [1], and detach the upper cover [2].

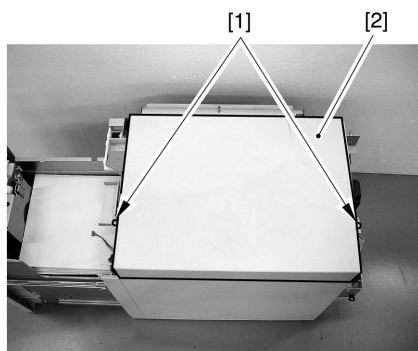

F-4-60

4.3.1.6 Removing the Deck Pickup Unit

0002-4967

- 1) Detach the deck release grip [1] in upward direction.
- 2) Disconnect the 2 connectors [2], and remove the 5 screws [3].
- 3) Detach the pickup harness [4].
- 4) Remove the deck pickup unit [5].

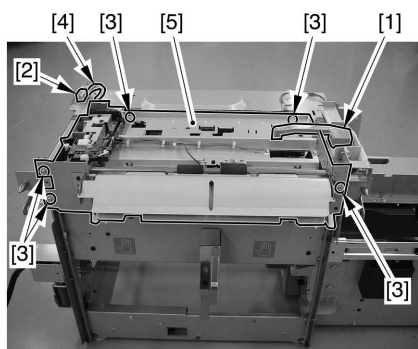

F-4-61

⚠ When mounting the deck pickup unit [1], tighten

the 3 screws [2] first and then the remaining 2 screws [3].

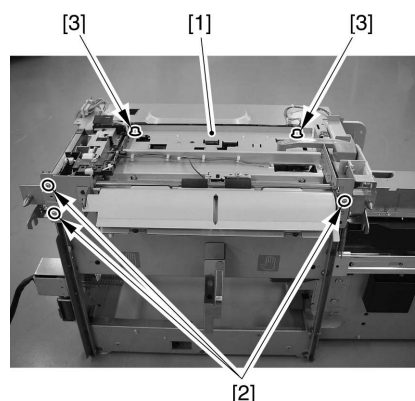

F-4-62

4.3.2 Deck Pickup Roller

4.3.2.1 Removing the Left Rear Cover

0002-4930

- 1) Free the deck from its host machine.
- 2) Remove the 2 screws [1] and 2 self-tapping screws [3]; then, detach the left rear cover [2].

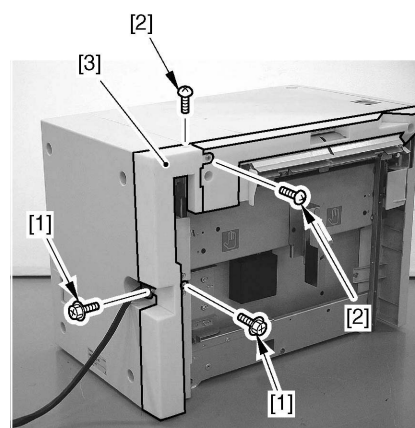

F-4-63

4.3.2.2 Removing the Left Upper Cover

0002-4937

- 1) Remove the 2 screws [1], and detach the left upper cover.

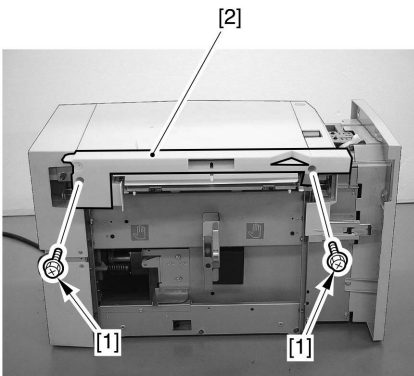

F-4-64

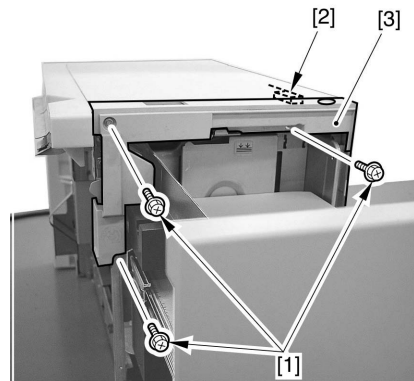

F-4-66

4.3.2.3 Removing the Rear Cover

0002-4947

- 1) Remove the 2 binding screws [1] and the 4 RS tightening screws [3]; then, detach the rear cover [2].

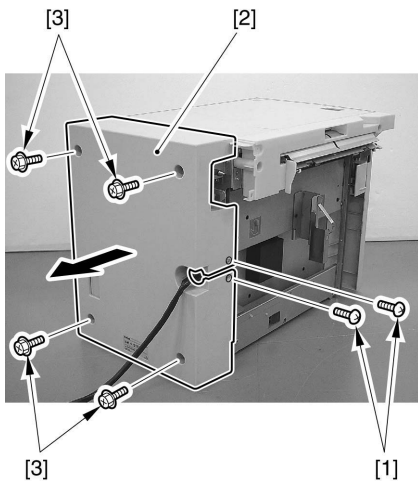

F-4-65

4.3.2.4 Removing the Front Cover (upper)

0002-4954

- 1) Remove the 3 screws [1], and disconnect the connector; then, detach the front cover (upper) [3].
- ⚠** When mounting the front cover (upper), be sure that the harness to the open switch PCB is not trapped and all connectors are properly connected.

4.3.2.5 Removing the Upper Cover

0002-4958

- 1) Remove the 2 screws [1], and detach the upper cover [2].

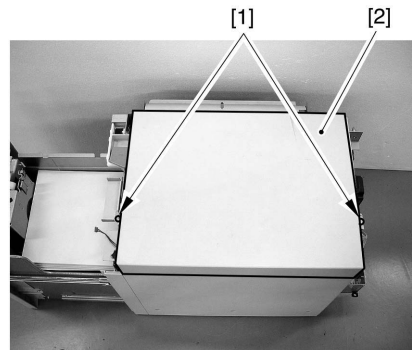

F-4-67

4.3.2.6 Removing the Deck Pickup Unit

0002-4968

- 1) Detach the deck release grip [1] in upward direction.
- 2) Disconnect the 2 connectors [2], and remove the 5 screws [3].
- 3) Detach the pickup harness [4].
- 4) Remove the deck pickup unit [5].

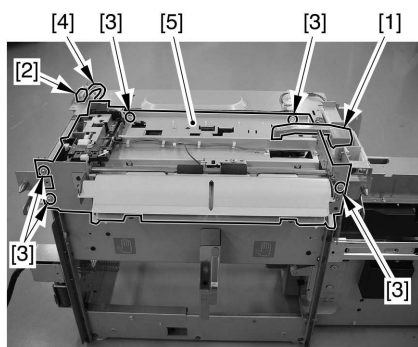

F-4-68

⚠ When mounting the deck pickup unit [1], tighten the 3 screws [2] first and then the remaining 2 screws [3].

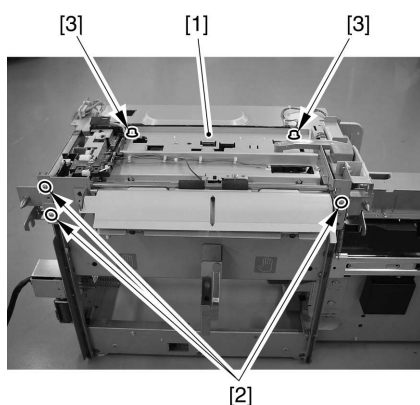

F-4-69

4.3.2.7 Removing the Deck

Pickup Roller [0001-1214](#)

1) Turn over the deck pickup unit; then, remove the resin ring [1] (1 each) and 2 deck pickup rollers [2].

⚠ The pickup roller has its own orientation (direction of rotation), requiring care when mounting it.

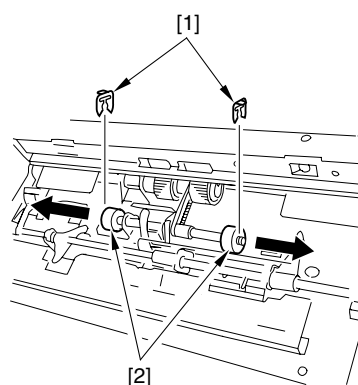

F-4-70

4.3.2.8 Points to Note When

Mounting the Pickup Roller [0001-1216](#)

Front of the Machine (collar [3]: silver in color)

The pickup roller has its own orientation. When mounting the deck pickup roller [2] found at the front of the machine, be sure that the marking [4] on the collar [3] is toward the front of the machine and the marking [5] on the side of the roller is toward the rear of the machine.

Rear of the Machine (collar [3]: gold in color)

The pickup roller has its own orientation. When mounting the deck pickup roller [2] at the rear of the machine, be sure that the marking [4] on the collar and the marking [5] on the side of the roller are toward the rear of the machine.

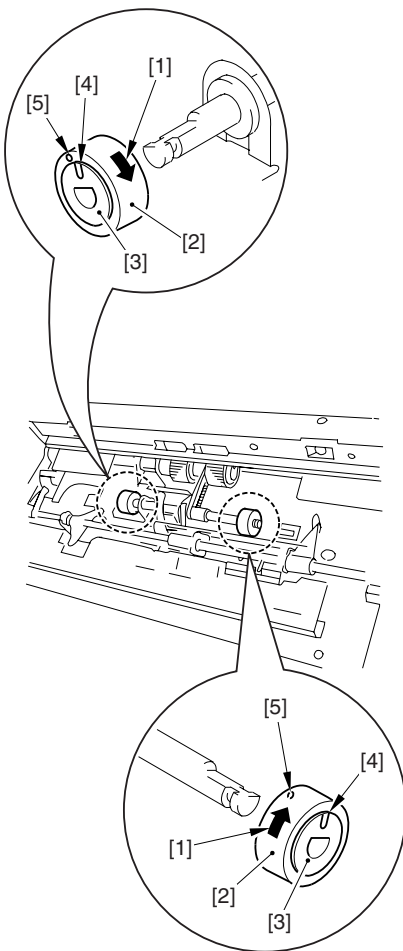

F-4-71

4.3.3 Deck Pickup/Feed Roller

4.3.3.1 Removing the Left Rear Cover

0002-4932

- 1) Free the deck from its host machine.
- 2) Remove the 2 screws [1] and 2 self-tapping screws [3]; then, detach the left rear cover [3].

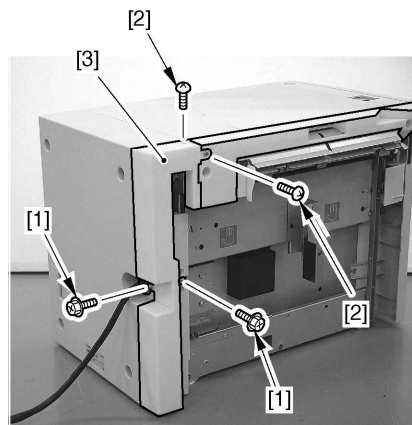

F-4-72

4.3.3.2 Removing the Left Upper Cover

0002-4938

- 1) Remove the 2 screws [1], and detach the left upper cover.

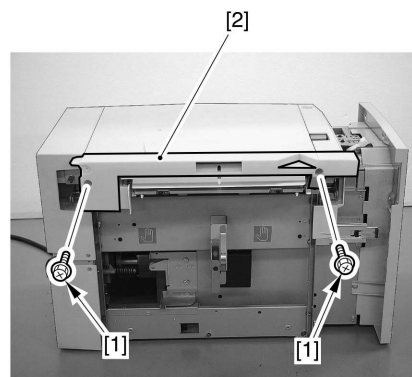

F-4-73

4.3.3.3 Removing the Rear Cover

0002-4948

- 1) Remove the 2 binding screws [1] and the 4 RS tightening screws [3]; then, detach the rear cover [2].

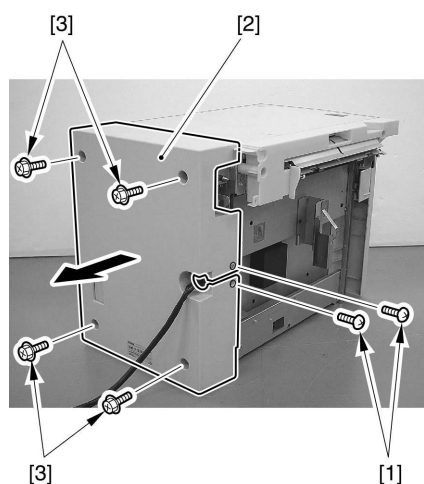

F-4-74

4.3.3.4 Removing the Front Cover (upper)

0002-4955

- 1) Remove the 3 screws [1], and disconnect the connector; then, detach the front cover (upper) [3].

⚠ When mounting the front cover (upper), be sure that the harness to the open switch PCB is not trapped and all connectors are properly connected.

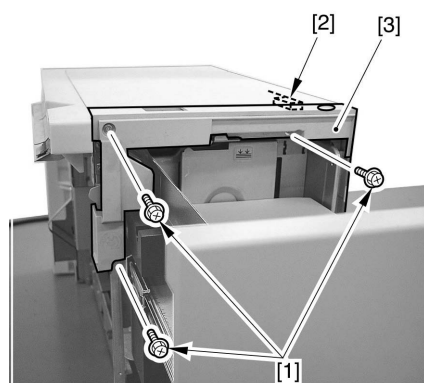

F-4-75

4.3.3.5 Removing the Upper Cover

0002-4960

- 1) Remove the 2 screws [1], and detach the upper cover [2].

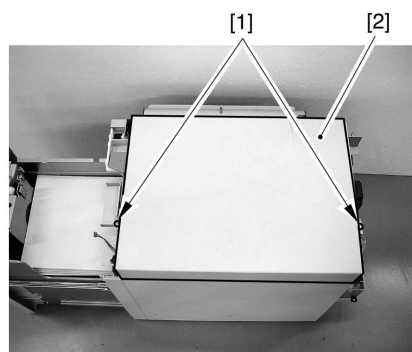

F-4-76

4.3.3.6 Removing the Deck Pickup Unit

0002-4970

- 1) Detach the deck release grip [1] in upward direction.
- 2) Disconnect the 2 connectors [2], and remove the 5 screws [3].
- 3) Detach the pickup harness [4].
- 4) Remove the deck pickup unit [5].

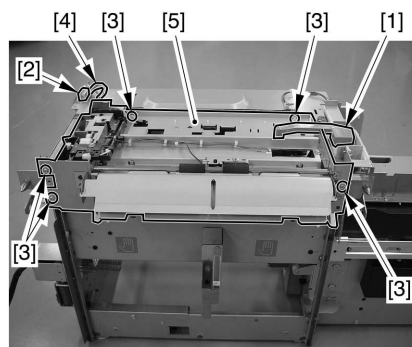

F-4-77

⚠ When mounting the deck pickup unit [1], tighten the 3 screws [2] first and then the remaining 2 screws [3].

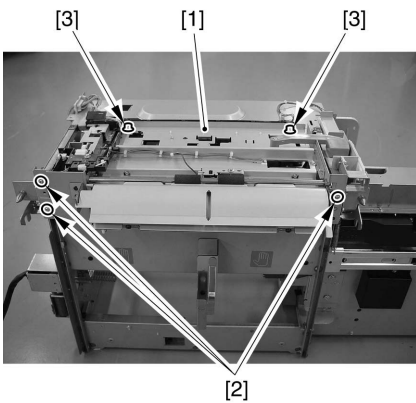

F-4-78

4.3.3.7 Removing the Deck Pickup/Feed Roller

0001-1218

- 1) Remove the resin ring [1], and detach the deck pickup/feed roller [2] and the drive belt [3] to the front.

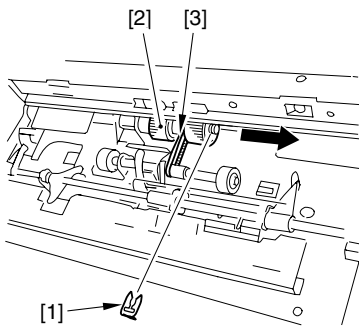

F-4-79

4.3.3.8 Points to Note When Mounting the Deck Pickup/Feed Roller

0001-1264

When mounting the deck pickup/feed roller [1], be sure that the belt pulley [2] is toward the front of the machine. There is no specific orientation to observe when fitting the pickup/feed roller rubber to the pickup/feed roller shaft.

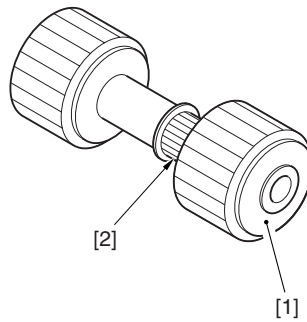

F-4-80

4.3.4 Deck Separation Roller

4.3.4.1 Removing the Deck Separation Roller

0001-1251

- 1) Free the deck from its host machine, and remove the 2 screws [1] and the separation roller support plate [2].

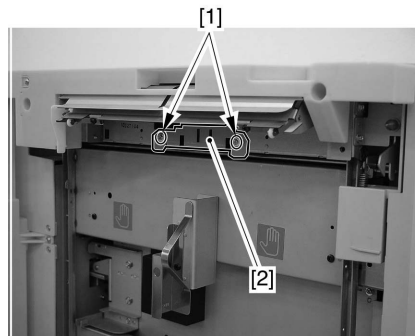

F-4-81

- 2) Detach the pickup roller [1] from the holder [2].

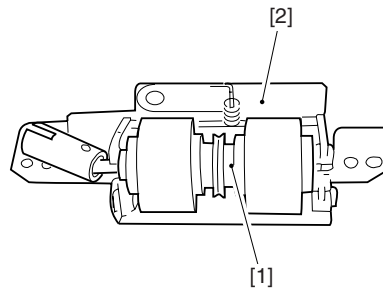

F-4-82

3) Detach the shaft [1] in the direction of the arrow.

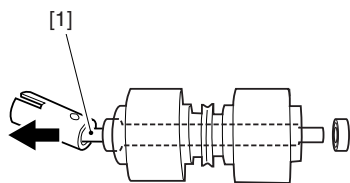

F-4-83

⚠The urethane sponge segment of the deck separation roller is pink immediately after foaming; it changes in color from pink to orange and then to yellow as time passes, accelerated if exposed to light. This is a general characteristic of a urethane sponge, and will not affect its performance. The part is not identified by its color, and there are not multiple parts classified according to color.

4.4 Electrical System

4.4.1 Deck Driver PCB

4.4.1.1 Removing the Left Rear Cover

0002-4933

- 1) Free the deck from its host machine.
- 2) Remove the 2 screws [1] and 2 self-tapping screws [3]; then, detach the left rear cover [2].

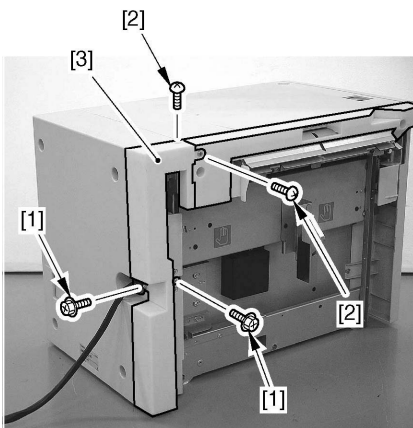

F-4-84

4.4.1.2 Removing the Rear Cover

0002-4949

- 1) Remove the 2 binding screws [1] and the 4 RS tightening screws [3]; then, detach the rear cover [2].

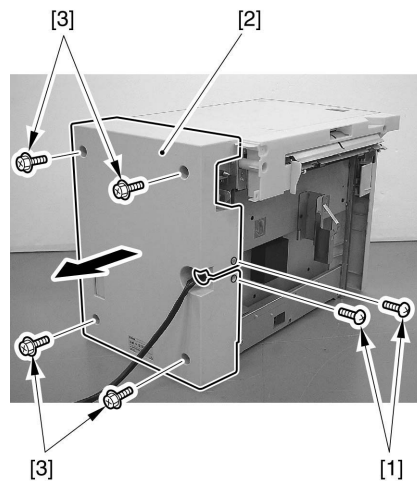

F-4-85

4.4.1.3 Removing the Deck Driver PCB

0001-1256

- 1) Disconnect the 8 connectors [1], and remove the 4 screws [2]; then, detach the deck driver PCB [3].

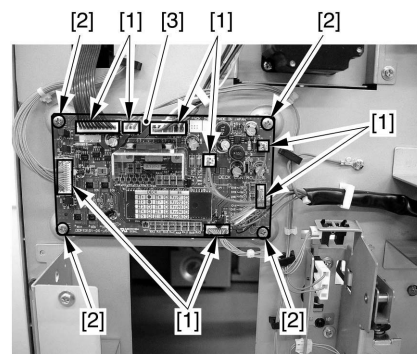

F-4-86

4.4.2 Open Switch PCB

4.4.2.1 Opening the Compartment

0002-6237

- 1) Push the deck release grip [1] to free the deck from its host machine; then, push down the latch plate [2] found at the left rear to open the compartment.

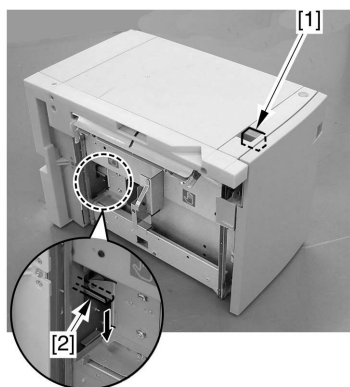

F-4-87

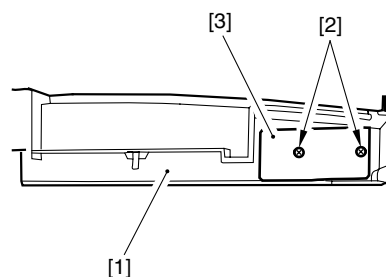

F-4-89

4.4.2.2 Removing the Front

Cover (upper) 0002-6240

- 1) Remove the 3 screws [1], and disconnect the connector; then, detach the front cover (upper) [3].

⚠ When mounting the front cover (upper), be sure that the harness to the open switch PCB is not trapped and all connectors are properly connected.

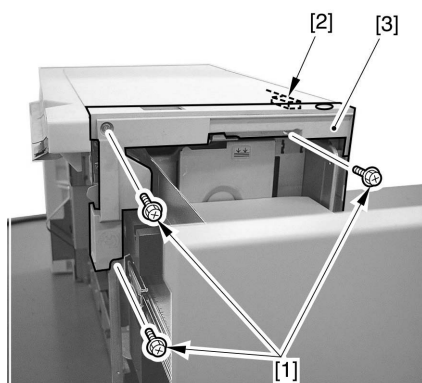

F-4-88

4.4.2.3 Removing the Open

Switch PCB 0001-1257

- 1) Remove the 2 screws [2] from inside the front cover (upper) [1], and detach the open switch PCB [3].

Chapter 5 Maintenance

Contents

5.1 Maintenance and Inspection	5-1
5.1.1 Periodically Replaced Parts	5-1
5.1.1.1 Periodically Replaced Parts	5-1
5.1.2 Durables	5-1
5.1.2.1 Durables	5-1
5.2 Adjustment	5-2
5.2.1 Basic Adjustment	5-2
5.2.1.1 Mounting the Deck Feed Roller	5-2
5.2.1.2 Adjusting the Deck Separation Roller Pressure	5-2
5.2.1.3 Using the Adjuster	5-2
5.2.1.4 Using the Roll Support Plate	5-3
5.2.1.5 Adjusting the Height of the Side Roll	5-3
5.2.1.6 Routing the Lifter Cable	5-4
5.2.2 Adjustment at Time of Parts Replacement	5-5
5.2.2.1 Positioning the Deck Pickup Roller Release Solenoid (SLID)	5-5
5.3 Outline of Electrical Components	5-7
5.3.1 Sensor-Motor-Clutch -Solenoid-PCB-Others	5-7

5.1 Maintenance and Inspection

5.1.1 Periodically Replaced Parts

5.1.1.1 Periodically Replaced Parts

0001-8501

The Side Paper Deck-Q1 does not have parts that require periodical replacement.

5.1.2 Durables

5.1.2.1 Durables

0001-8559

T-5-1

as of May 2003					
Ref.	Parts name	Parts No.	Q'ty	Life (prints)	Remarks
[1]	Pickup roller (front)	FF5-7829	1	250,000	actual number of prints
[2]	Pickup roller (rear)	FF5-7830	1	250,000	actual number of prints
[3]	Feed roller	FF5-7541	1	250,000	actual number of prints
[4]	Separation roller	FB2-7777	1	250,000	actual number of prints

5.2 Adjustment

5.2.1 Basic Adjustment

5.2.1.1 Mounting the Deck Feed Roller

0002-1085

When mounting the deck pickup/feed roller [1], be sure that the belt pulley [2] is toward the machine's front.

The pickup/feed roller rubber may be fitted to the pickup/feed roller shaft in any orientation.

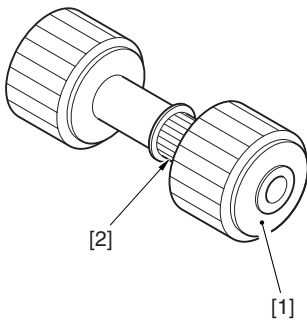

F-5-1

5.2.1.2 Adjusting the Deck Separation Roller Pressure

0001-1253

If pickup failure or multiple feeding tends to occur when the deck is used as the source of paper, adjust the position of the pressure spring [2] of the deck separation roller [1]:

- if pickup failure occurs, move the spring in the direction of arrow A.
- if multiple feeding occurs, move the spring in the direction of arrow B.

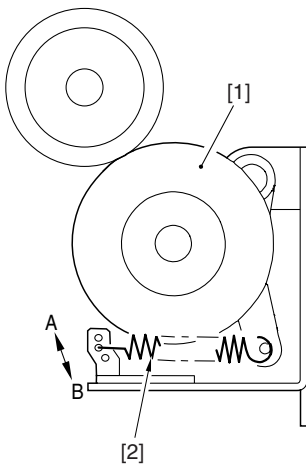

F-5-2

5.2.1.3 Using the Adjuster

0002-1086

- 1) When you have moved the machine, tighten the front and rear adjusters [1] to fix the printer unit in place on the floor.

⚠ If the adjusters are correctly used, the machine can start to show faults. Be sure that the feet of the adjusters are in contact with the floor.

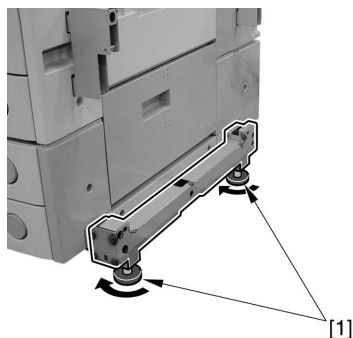

F-5-3

5.2.1.4 Using the Roll Support Plate

0002-1125

- 1) Take note of the position of the front cover with reference to the index marked near the mounting screw [1].
- 2) Loosen the 4 screws, and detach the front cover [2] toward the front.

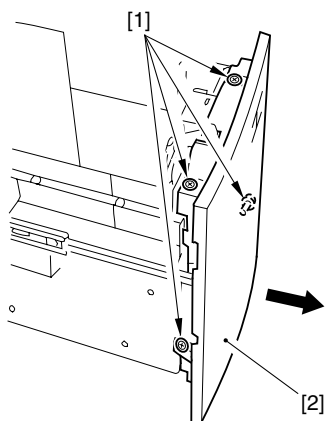

F-5-4

- 3) Push in the compartment, and attach the paper deck to its host machine.
- 4) Tighten the 4 screws [3].
- 5) With the compartment open, adjust the height of the roll support plate [2] so that the distance between the roll [1] and the floor A is about 3 mm; then, tighten the screws.
- 6) Attach the front cover.

5.2.1.5 Adjusting the Height of the Side Roll

0002-1088

Making Pre-Checks

- 1) Detach the machine from its host machine, and then attach it back to the host machine, while checking if the impact of attachment causes the host machine to become displaced or causes the machine to wobble. If so, adjust the height of the side roll as follows; otherwise, skip the adjustment work.

Adjustment Work

- 1) Connect the machine to its host machine.
- 2) Take out the paper from the deck.
- 3) Detach the machine's right cover.

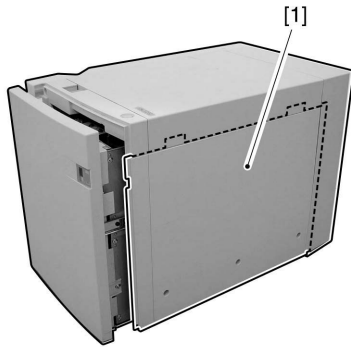

F-5-5

- 4) Loosen the 2 fixing screws [2] of the side roll [1].
 - 5) Keep the side roll on the floor, and tighten the fixing screws.
- At this time, be sure that the left and right screws are in keeping with the index.

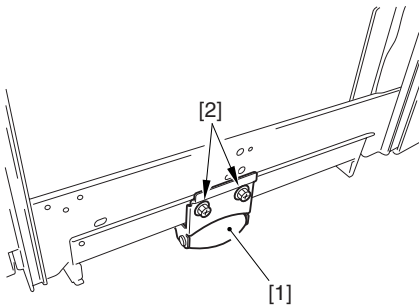

F-5-6

- 6) Detach and then attach the machine from and to its host machine.
If the movement is not too heavy, attach the machine's right cover, and put back the paper to end the work.
If the movement is rather heavy, go on to the next step.
- 7) Check the position of the side roll index.
- 8) Loosen the side roll fixing screw.
- 9) While referring to the index, tighten the fixing screw while keeping the side roll up by 1 mm.
- 10) Attach the right cover, and put the paper back in the deck.

5.2.1.6 Routing the Lifter Cable

0002-1151

- 1) Check to be sure that the lifter driver shaft [1] and the lifter [2] are fixed in place by the 2 hex screwdrivers [4] and a hex wrench [3] or the like.
- 2) Secure the 4 cable fixing plates [5] in place to the lifter using 2 screws each.
- 3) Hook the lifter cable [6] on the 4 pulleys [7].

- 4) Hook the ball of the lifter cable on the 2 pulleys found at the front/rear of the lifter drive shaft; then, wind the cable about 1.5 times along the groove of the pulley.

At this time, see to it that the lifter cable is taut just enough to lift the long screwdrivers used to keep the lifter in place.

- 5) Secure the 2 pulleys [5] in place to the lifter drive shaft using a set screw [9] (1 each).
- 6) After mounting all pulleys you have removed to the lifter drive shaft, measure the height A from the base plate of the compartment to the top surface of the lifter at several points, thereby making sure that the lifter is level.

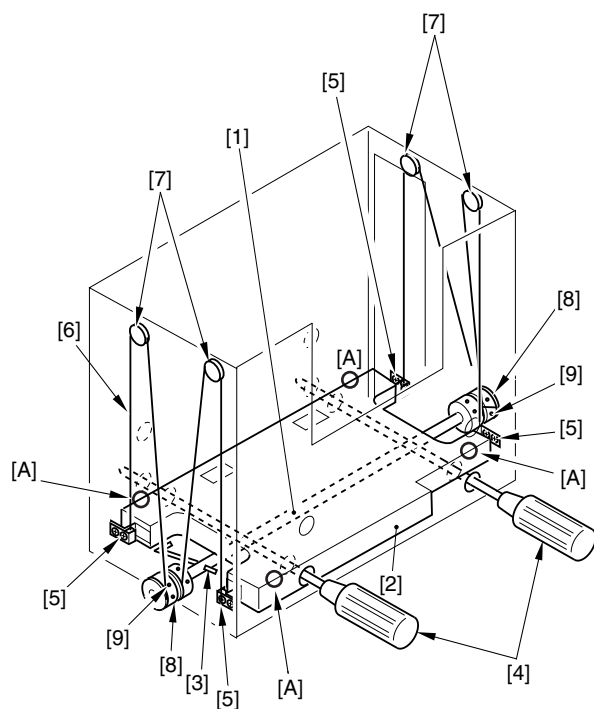

F-5-7

5.2.2 Adjustment at Time of Parts Replacement

5.2.2.1 Positioning the Deck Pickup Roller Release Solenoid (SL1D)

0001-1254

Before removing the deck pickup roller release solenoid [1] from the support plate, take note of the position of the 2 solenoid fixing screws [2] with reference to the index on the support plate. Or, mark the position of the solenoid on its own using scribe on the support plate. (If you are mounting the solenoid on its own, be sure to secure it in its initial position.)

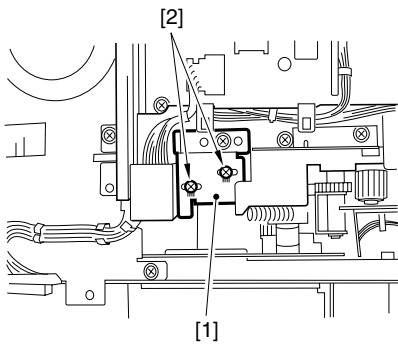

F-5-8

5.3 Outline of Electrical Components

5.3.1 Sensor-Motor-Clutch -Solenoid-PCB-Others

0003-9510

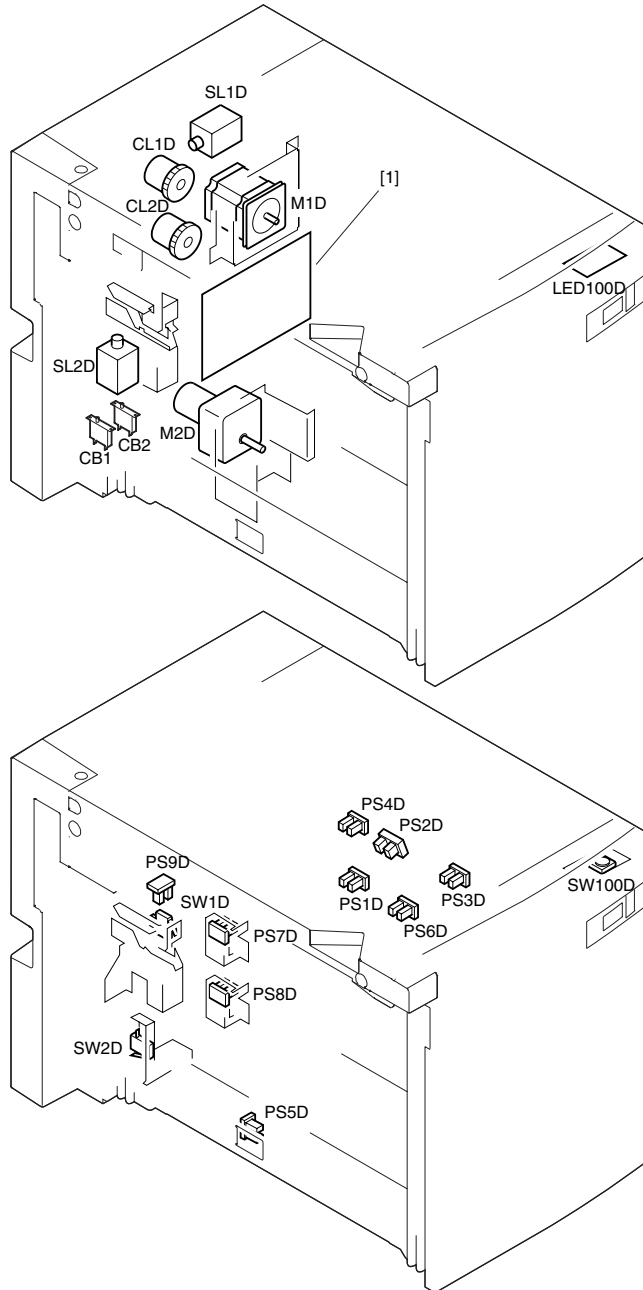

F-5-9

T-5-2

Item	Notation	Name
Clutch	CL1D	Deck feeder clutch
	CL2D	Deck pickup clutch
Solenoid/Switch	SL1D	Deck pickup roller release solenoid
	SL2D	Deck open solenoid
	SW1D	Deck open sensing switch
	SW2D	Deck lifter lower limit sensing switch
	SW100D	Deck open switch
	LED100 D	Deck open indication
	Motor	M1D
M2D		Deck lifter motor
Sensor	PS1D	Deck feeder sensor
	PS2D	Deck paper-out sensor
	PS3D	Deck lifter upper limit sensor
	PS4D	Deck lifter position sensor
	PS5D	Deck set sensor
	PS6D	Deck pickup sensor
	PS7D	Deck paper level sensor
	PS8D	Deck paper replenishing position sensor
	PS9D	Deck open sensor
Circuit Breaker	CB1	Circuit breaker 1
	CB2	Circuit breaker 2

Chapter 6 Service Mode

Contents

6.1 Outline	6-1
6.1.1 Alarm Code	6-1

6.1 Outline

6.1.1 Alarm Code

0001-0838

The presence of the following will be indicated in service mode (COPIER>DISPLAY.ALARM2) in the form of an alarm code upon detection:

T-6-1

Sensor No.	Description	Code
PS6D	pickup signal is not detected	40018
PS4D	deck lifter UP signal is not detected	40008

Chapter 7 Error Code

Contents

7.1 Overview	7-1
7.1.1 Error Code	7-1

7.1 Overview

7.1.1 Error Code

0001-0823

There is no error code that is unique to the paper deck. All codes used for the paper deck are in keeping with the error codes used for its host machine.

Nov 13 2003

Canon